



ZEPHYR[®]
TOOL
GROUP
LOK-FAST

The image displays two pieces of industrial tooling against a dark blue background. The upper tool is a complex assembly with a cylindrical handle, a rectangular body, and a long, thin, tapered shaft. The lower tool is similar but features a more prominent cylindrical section and a different handle design. Both tools are made of dark metal and show signs of use.

Frangible Collar Tooling



LOK-FAST

Hi-Lok® Type Fastener Installation Tools

Quick Release System (QRS®)	04
QRS® Socket Assemblies	05
L-Head Assemblies	
L-Head Assembly, Short with Extended Socket	06
L-Head Assembly, Short without Extended Socket	06
L-Head Assembly, Long with Extended Socket	07
L-Head Assembly, Long without Extended Socket	07
Straight Drive Assembly	08
Straight Drive Socket Assemblies	08
Ratchet Assemblies	
Straight Ratchet without Extended Socket	09
Straight Ratchet with Extended Socket	09
Offset Ratchet without Extended Socket	10
Offset Ratchet with Extended Socket	10
Ratchet Hand Tools	11
Glossary	11 - 12

Quick Change System

Hi-Lok® Type Fastener Tools

Quick Change System Introduction	14
Quick Change Removal Socket	15
Quick Change Installation Socket	16
Quick Change Installation, Hand Tool Assembly	17
Quick Change Removal, Hand Tool Assembly	18
Quick Change Pneumatic Tool Kits	19 - 21
Glossary	22

ZEPHYR[®]
T O O L
G R O U P



TOOLS ENGINEERED TO PERFORM

ZEPHYR[®]
SCREWDRIVING TOOLS

KWIK-LOK[™]
TEMPORARY FASTENERS

ZEPHYR[®]
AEROSPACE HAND & PNEUMATIC TOOLS

LOK-FAST[™]
AEROSPACE FASTENER TOOLS

Martin[™]
AIRCRAFT TOOL

LOK-FAST

ZEPHYR TOOL GROUP

201 Hindry Avenue
Los Angeles, CA 90301
Tel. 310-410-4907 ■ Email: sales@zephyrtoolgroup.com ■ zephyrtoolgroup.com

ZEPHYR[®]
T O O L
G R O U P



TOOLS ENGINEERED TO PERFORM

ZEPHYR[®]
SCREWDRIVING TOOLS

KWIK-LOK[™]
TEMPORARY FASTENERS

ZEPHYR[®]
AEROSPACE HAND & PNEUMATIC TOOLS

LOK-FAST[™]
AEROSPACE FASTENER TOOLS

Martin[™]
AIRCRAFT TOOL

LOK-FAST

Hi-Lok[®] Type Fastener Installation Tools

ZEPHYR TOOL GROUP

201 Hindry Avenue
Los Angeles, CA 90301
Tel. 310-410-4907 ▪ Email: sales@zephyrtoolgroup.com ▪ zephyrtoolgroup.com

Page 3
11/15/18



LOK-FAST

Quick Release System[®]

The Quick-Release System (QRS[®]) is an innovative, proprietary system offered by LOK-FAST to install Hi-Loks[®] and other non-interference fit fasteners. QRS[®] is a hex tip holder assembly providing a higher strength quick-change hex tip which allows the operator to change the tip key both quickly and at the work station with no additional tooling or conversion kits. This process eliminates costly down time and removes the need to return a tool to the tool crib to replace a broken hex tip.

Benefits of the Quick-Release System (QRS[®])

- Fewer Holders - Only One Holder for All Hex Keys
- Quick Change of Hex Keys with tool fully assembled
- No Tools or Conversion Kits Required
- Tips Will *Not* Jam in the Holder
- Sealant Contamination is Minimized
- Economical to Implement - May Be Used With Existing Drivers

Part Description

1. Retaining Shaft
2. Nylon Washer
3. Hex Tip Holder
4. Hex Tip
5. QRS[®] Holder Assembly

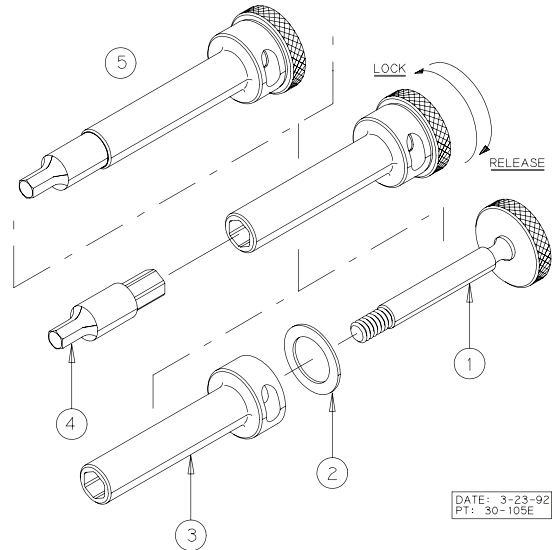

How It Works:

The hex tip is held into a fitted holder by a threaded retaining shaft. The hex tip is drawn into the holder when the retaining shaft is rotated clockwise, and is expelled when shaft is rotated counterclockwise. If the hex tip breaks this action prevents the tip from being jammed into the holder.

Installation:

1. Slide retaining shaft through the back of the holder
2. Insert holder assembly into the drive gear or socket
3. Insert spring into the slot in the assembly, this will hold the retaining shaft in place.
4. The hex tip can now be inserted. Do not overtighten. The nylon washer will prevent the shaft from vibrating loose
5. Installation is now complete

To Replace Hex Key:

1. Rotate the retaining shaft until the hex tip falls out
2. Replace and tighten retaining shaft

To Replace Hex Key Size:

Follow same procedure as when replacing broken hex tip



Quick Release System[®]



How To Order:

1. Determine the hex recess size of the fastener pin to be installed (column 1)
2. Determine the hex size of the driving collar to be installed onto the pin (column 2).
3. Select the socket length required. Use a dash number equal or greater than the extension required.

Example: **QSA281-05-5**

- socket hex size is 9/32"
- socket length 1/2"
- hex tip size is 1/16"

Part number includes the following

1. 1/2" retaining shaft
2. 1/2" holder
3. Retaining clip
4. 1/2" long extended socket with 9/32" hex recess
5. 5/64" QRS[®] hex tip

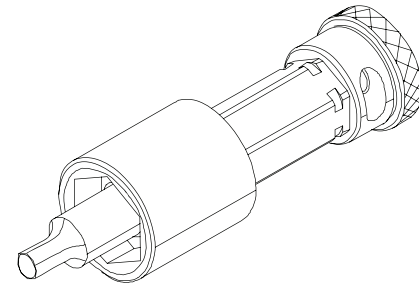

Hex Tip	Socket Hex	Complete Part #	Socket	Holder	Retaining Shaft
1/16" QRK - 5	7/32	QSA218 - (E) - 5	HS - 22 - (E)	QRH - (E)	QRS - (E)
	1/4	QSA250 - (E) - 5	HS - 25 - (E)		
	9/32	QSA281 - (E) - 5	HS - 28 - (E)		
	5/16	QSA312 - (E) - 5	HS - 31 - (E)		
	11/32	QSA343 - (E) - 5	HS - 34 - (E)		
5/64" QRK - 6	7/32	QSA218 - (E) - 6	HS - 22 - (E)	QRH - (E)	QRS - (E)
	1/4	QSA250 - (E) - 6	HS - 25 - (E)		
	9/32	QSA281 - (E) - 6	HS - 28 - (E)		
	5/16	QSA312 - (E) - 6	HS - 31 - (E)		
	11/32	QSA343 - (E) - 6	HS - 34 - (E)		
3/32" QRK - 8	3/8	QSA375 - (E) - 6	HS - 37 - (E)	QRH - (E)	QRS - (E)
	5/16	QSA312 - (E) - 8	HS - 31 - (E)		
	11/32	QSA343 - (E) - 8	HS - 34 - (E)		
	7/16	QSA437 - (E) - 8	HS - 43 - (E)		
1/8" QRK - 10	7/16	QSA437 - (E) - 10	HS - 43 - (E)	QRH - (E)	QRS - (E)
	9/16	QSA562 - (E) - 10	HS - 56 - (E)		
	1/2	QSA500 - (E) - 10	HS - 50 - (E)		

(E)	Socket Length
04	0.25"
05	0.50"
07	0.75"
10	1.00"
15	1.50"
20	2.00"
25	2.50"
30	3.00"



TOOLS ENGINEERED TO PERFORM

L-Head Assembly, Short Tube

Reversible With Extended Socket

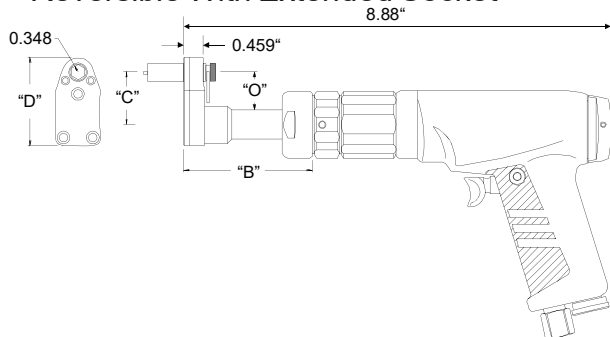

(R) Motor RPM	(E) Socket Length	(D) Front/Back Drive		
3 = 350	1 = flush	B = back		
5 = 540	04 = 0.25"	() = front		
	05 = 0.50"			
	07 = 0.75"			
	10 = 1.0"			
	15 = 1.5"			
	20 = 2.0"			
	25 = 2.5"			
	30 = 3.0"			

(G) Offset Number	"B"	"C"	"D"	"O"
3		1.30	2.20	0.88
4	2.125	2.00	2.80	1.70
5		2.80	3.60	2.40
7		4.30	5.10	3.90

To Order:

1. Determine the RPM required.
2. Determine the needed offset.
2. Determine the QRS[®] Socket Hex Size needed.
3. Determine the length of the Required Socket.

Example: **IQLA35S22-10-5B**

- IQLA : Master Part Number
- 350 RPM motor.
- 5 gear L-Head.
- Short Tube Length.
- 7/32 socket.
- 1.0" extended socket, with QRS System
- Back drive.

Hex Tip	Socket Hex	Complete Tool Part #	Head Assy #
1/16 QRK - 5	7/32	IQLA(R)(G)S22 - (E) - 5(D)	IQL(G)S22 - (E) - 5
	1/4	IQLA(R)(G)S25 - (E) - 5(D)	IQL(G)S25 - (E) - 5
	9/32	IQLA(R)(G)S28 - (E) - 5(D)	IQL(G)S28 - (E) - 5
	5/16	IQLA(R)(G)S31 - (E) - 5(D)	IQL(G)S31 - (E) - 5
	11/32	IQLA(R)(G)S34 - (E) - 5(D)	IQL(G)S34 - (E) - 5
5/64 QRK - 6	7/32	IQLA(R)(G)S22 - (E) - 6(D)	IQL(G)S22 - (E) - 6
	1/4	IQLA(R)(G)S25 - (E) - 6(D)	IQL(G)S25 - (E) - 6
	9/32	IQLA(R)(G)S28 - (E) - 6(D)	IQL(G)S28 - (E) - 6
	5/16	IQLA(R)(G)S31 - (E) - 6(D)	IQL(G)S31 - (E) - 6
	11/32	IQLA(R)(G)S34 - (E) - 6(D)	IQL(G)S34 - (E) - 6
3/8 QRK - 8	3/8	IQLA(R)(G)S37 - (E) - 6(D)	IQL(G)S37 - (E) - 6
	5/16	IQLA(R)(G)S31 - (E) - 8(D)	IQL(G)S31 - (E) - 8
	11/32	IQLA(R)(G)S34 - (E) - 8(D)	IQL(G)S34 - (E) - 8
	7/16	IQLA(R)(G)S43 - (E) - 8(D)	IQL(G)S43 - (E) - 8

L-Head Assembly, Short Tube

Reversible Flush w/ Flush Drive Socket

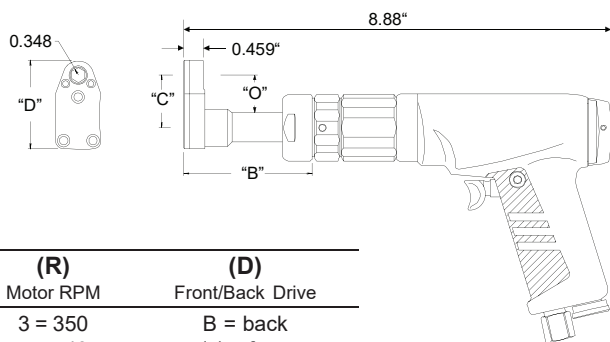

(R) Motor RPM	(D) Front/Back Drive
3 = 350	B = back
5 = 540	() = front

(G) Offset Number	"B"	"C"	"D"	"O"
3		1.30	2.20	0.88
4	2.125	2.00	2.80	1.70
5		2.80	3.60	2.40
7		4.30	5.10	3.90

To Order:

1. Determine the RPM required.
2. Determine the needed offset.
2. Determine the Drive Socket Hex Size needed.

Example: **IL3-5-22-S**

- 350 RPM motor
- 5 gear L-Head
- 7/32 flush socket
- Short tube length

Drive Gear	Complete Part #	Head Assy #
7/32	IL(R)(G) - 22 - S	ILH(G) - 22 - S
1/4	IL(R)(G) - 25 - S	ILH(G) - 25 - S
9/32	IL(R)(G) - 28 - S	ILH(G) - 28 - S
5/16	IL(R)(G) - 31 - S	ILH(G) - 31 - S
11/32	IL(R)(G) - 34 - S	ILH(G) - 34 - S
3/8	IL(R)(G) - 37 - S	ILH(G) - 37 - S



L-Head Assembly, Long Tube

Reversible With Extended Socket

LOK-FAST

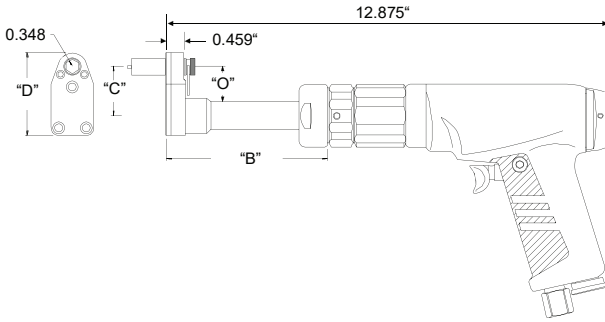

To Order:

1. Determine the RPM required.
2. Determine the needed offset.
3. Determine the QRS[®] Socket Hex Size needed.
4. Determine the length of the Required Socket .

Example: **IQLA55L22-5-5**

- IQLA : Master Part Number.
- 450 RPM motor.
- 5 gear L-Head.
- Long Tube Length.
- 7/32 socket.
- 0.5" extended socket, with QRS System
- Front drive.

(R) Motor RPM	(E) Socket Length	(D) Front/Back Drive
3 = 350	1 = flush	B =
5 = 540	04 = 0.25"	() = front
	05 = 0.50"	
	07 = 0.75"	
	10 = 1.0"	
	15 = 1.5"	
	20 = 2.0"	
	25 = 2.50"	
	30 = 3.0"	

(G) Offset Number	"B"	"C"	"D"	"O"
3		1.30	2.20	0.88
4	6.00	2.00	2.80	1.70
5		2.80	3.60	2.40
7		4.30	5.10	3.90

Hex Tip	Socket Hex	Complete Tool Part #	Head Assy #
1/16 QRK - 5	7/32	IQLA(R)(G)L22 - (E) - 5(D)	IQL(G)L22 - (E) - 5
	1/4	IQLA(R)(G)L25 - (E) - 5(D)	IQL(G)L25 - (E) - 5
	9/32	IQLA(R)(G)L28 - (E) - 5(D)	IQL(G)L28 - (E) - 5
	5/16	IQLA(R)(G)L31 - (E) - 5(D)	IQL(G)L31 - (E) - 5
	11/32	IQLA(R)(G)L34 - (E) - 5(D)	IQL(G)L34 - (E) - 5
5/64 QRK - 6	7/32	IQLA(R)(G)L22 - (E) - 6(D)	IQL(G)L22 - (E) - 6
	1/4	IQLA(R)(G)L25 - (E) - 6(D)	IQL(G)L25 - (E) - 6
	9/32	IQLA(R)(G)L28 - (E) - 6(D)	IQL(G)L28 - (E) - 6
	5/16	IQLA(R)(G)L31 - (E) - 6(D)	IQL(G)L31 - (E) - 6
	11/32	IQLA(R)(G)L34 - (E) - 6(D)	IQL(G)L34 - (E) - 6
3/8 QRK - 8	3/8	IQLA(R)(G)L37 - (E) - 6(D)	IQL(G)L37 - (E) - 6
	5/16	IQLA(R)(G)L31 - (E) - 8(D)	IQL(G)L31 - (E) - 8
	11/32	IQLA(R)(G)L34 - (E) - 8(D)	IQL(G)L34 - (E) - 8
	3/8	IQLA(R)(G)L37 - (E) - 8(D)	IQL(G)L37 - (E) - 8
	7/16	IQLA(R)(G)L43 - (E) - 8(D)	IQL(G)L43 - (E) - 8

L-Head Assembly, Long Tube

Reversible Flush w/ Drive Socket

To Order:

1. Determine the RPM required.
2. Determine the needed offset.
2. Determine the Drive Socket Hex Size needed.

Example: **IL3-5-22-L**

- 350 RPM motor
- 5 gear L-Head
- 7/32 flush socket
- Long tube length

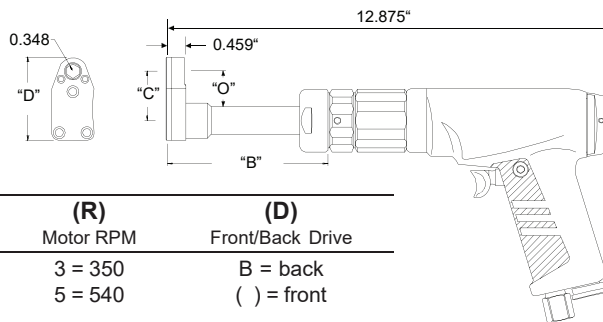

(R) Motor RPM	(D) Front/Back Drive
3 = 350	B = back
5 = 540	() = front

(G) Offset Number	"B"	"C"	"D"	"O"
3		1.30	2.20	0.88
4	6.00	2.00	2.80	1.70
5		2.80	3.60	2.40
7		4.30	5.10	3.90

Drive Gear	Complete Part #	Head Assy #
7/32	IL(R)(G) - 22 - L	ILH(G) - 22 - L
1/4	IL(R)(G) - 25 - L	ILH(G) - 25 - L
9/32	IL(R)(G) - 28 - L	ILH(G) - 28 - L
5/16	IL(R)(G) - 31 - L	ILH(G) - 31 - L
11/32	IL(R)(G) - 34 - L	ILH(G) - 34 - L
3/8	IL(R)(G) - 37 - L	ILH(G) - 37 - L



Straight Drive

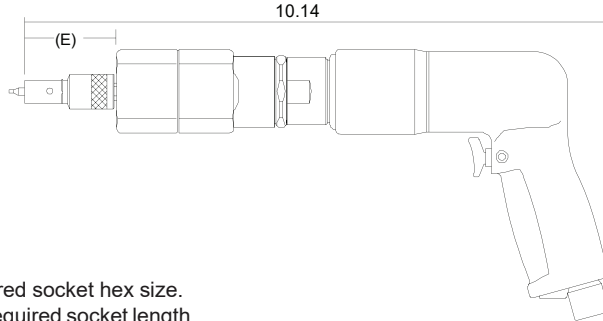

To Order:

1. Select the required socket hex size.
2. Determine the required socket length.
3. Determine the hex tip size.

Example: **SDA4 - 22 - 2 - 5**

- 400 rpm motor.
- 2.0" long socket with QRS® System.
- Including 1/16" hex tip.

(E) Length
2 = 2.0"
4 = 4.0"

Hex Tip	Socket Hex	Complete Tool Part #
1/16 QRK - 5	7/32	SDA4 - 22 - (E) - 5
	1/4	SDA4 - 25 - (E) - 5
	9/32	SDA4 - 28 - (E) - 5
	5/16	SDA4 - 31 - (E) - 5
	11/32	SDA4 - 34 - (E) - 5
5/64 QRK - 6	7/32	SDA4 - 22 - (E) - 6
	1/4	SDA4 - 25 - (E) - 6
	9/32	SDA4 - 28 - (E) - 6
	5/16	SDA4 - 31 - (E) - 6
	11/32	SDA4 - 34 - (E) - 6
3/8 QRK - 8	3/8	SDA4 - 37 - (E) - 6
	5/16	SDA4 - 31 - (E) - 8
	11/32	SDA4 - 34 - (E) - 8
3/8 QRK - 8	3/8	SDA4 - 37 - (E) - 8
	7/16	SDA4 - 43 - (E) - 8

Straight Drive Socket

To Order:

1. Select the required hex size of the socket.
2. Determine the required socket length.
2. Select the size for the hex tip.

Example: **SDSA22-2-5**

- 2.0" long socket, with QRS® System.
- Includes 1/16" hex tip.



(E) Length
2 = 2.0"
4 = 4.0"

Hex Tip	Socket Hex	Complete Tool Part #	Socket	Holder Assembly
1/16 QRK - 5	7/32	SDSA22(E)5	SDS - 22(E)	SDQRA
	1/4	SDSA25(E)5	SDS - 25(E)	
	9/32	SDSA28(E)5	SDS - 28(E)	
	5/16	SDSA31(E)5	SDS - 31(E)	
	11/32	SDSA34(E)5	SDS - 34(E)	
5/64 QRK - 6	7/32	SDSA22(E)6	SDS - 22(E)	SDQRA
	1/4	SDSA25(E)6	SDS - 25(E)	
	9/32	SDSA28(E)6	SDS - 28(E)	
	5/16	SDSA31(E)6	SDS - 31(E)	
	11/32	SDSA34(E)6	SDS - 34(E)	
3/8 QRK - 8	3/8	SDSA37(E)6	SDS - 37(E)	SDQRA
	5/16	SDSA31(E)8	SDS - 31(E)	
	11/32	SDSA34(E)8	SDS - 34(E)	
3/8 QRK - 8	3/8	SDSA37(E)8	SDS - 37(E)	SDQRA
	7/16	SDSA43(E)8	SDS - 43(E)	



Straight Ratchet Head
Flush

LOK-FAST

- To Order:**
1. Specify the RPM rating of the motor.
2. Determine the drive socket hex size.

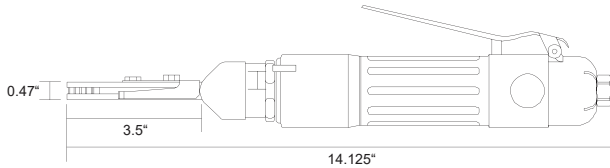

Example: **SR10 - 28**

- 1000 RPM motor.
- 9/32" flush socket.

(R) Motor RPM	Socket RPM	Socket Torque @ 90 PSI
4 = 400	45	360 in lbs
6 = 600	85	204 in lbs
10 = 1000	145	115 in lbs
15 = 1500	215	97 in lbs
30 = 3000	425	44 in lbs

Socket Hex	Complete Tool Part #	Head Assy #
7/32	SR(R) - 22	SRHA8200 - 22
1/4	SR(R) - 25	SRHA8200 - 25
9/32	SR(R) - 28	SRHA8200 - 28
5/16	SR(R) - 31	SRHA8200 - 31
11/32	SR(R) - 34	SRHA8200 - 34
3/8	SR(R) - 37	SRHA8200 - 37
7/16	SR(R) - 43	SRHA8200 - 43
9/32 thru hex	SR(R) - 932	SRHA8200 - 932

Straight Ratchet Head
With Flush or Extended Socket

- To Order:**
1. Determine the RPM required.
2. Determine the required socket hex size.
2. Determine the Drive Socket Size needed.

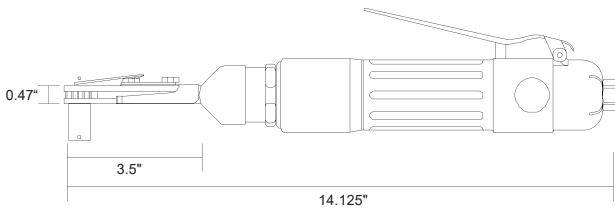

Example: **QSRA6 - 22 - 10 - 5**

- 600 RPM motor.
- 7/32" socket.
- 1.0" extended socket with QRS[®] System.
- Includes 1/16" hex tip.

(R) Motor RPM	Socket RPM	Socket Torque @ 90 PSI
4 = 400	45	360 in lbs
6 = 600	85	204 in lbs
10 = 1000	145	115 in lbs
15 = 1500	215	97 in lbs
30 = 3000	425	44 in lbs

Hex Tip	Socket Hex	Complete Tool Part #	Head Assy #
1/16 QRK - 5	7/32	QSRA(R) - 22 - (E) - 5	QSR - 22 - (E) - 5
	1/4	QSRA(R) - 25 - (E) - 5	QSR - 25 - (E) - 5
	9/32	QSRA(R) - 28 - (E) - 5	QSR - 28 - (E) - 5
	5/16	QSRA(R) - 31 - (E) - 5	QSR - 31 - (E) - 5
	11/32	QSRA(R) - 34 - (E) - 5	QSR - 34 - (E) - 5
5/64 QRK - 6	7/32	QSRA(R) - 22 - (E) - 6	QSR - 22 - (E) - 6
	1/4	QSRA(R) - 25 - (E) - 6	QSR - 25 - (E) - 6
	9/32	QSRA(R) - 28 - (E) - 6	QSR - 28 - (E) - 6
	5/16	QSRA(R) - 31 - (E) - 6	QSR - 31 - (E) - 6
	11/32	QSRA(R) - 34 - (E) - 6	QSR - 34 - (E) - 6
3/32 QRK - 8	3/8	QSRA(R) - 37 - (E) - 6	QSR - 37 - (E) - 6
	5/16	QSRA(R) - 31 - (E) - 8	QSR - 31 - (E) - 8
	11/32	QSRA(R) - 34 - (E) - 8	QSR - 34 - (E) - 8
3/8	3/8	QSRA(R) - 37 - (E) - 8	QSR - 37 - (E) - 8
	7/16	QSRA(R) - 43 - (E) - 8	QSR - 43 - (E) - 8

(E) Socket Length
1 = flush
4 = 0.25"
5 = 0.50"
7 = 0.75"
10 = 1.0"
15 = 1.5"
20 = 2.0"
25 = 2.50"
30 = 3.0"



20° Offset Ratchet Head
Flush

LOK-FAST

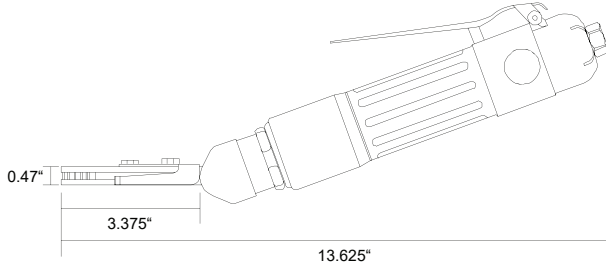

- To Order:
1. Specify the RPM rating of the motor.
 2. Determine the drive socket hex size.

Example: R1000 - 28

- 1000 RPM motor.
- 9/32" flush socket.

(R) Motor RPM	Socket RPM	Socket Torque @ 90 PSI
4=400	45	360 in lbs
6=600	85	204 in lbs
10=1000	145	115 in lbs
15=1500	215	97 in lbs
20=2000	285	85 in lbs

Socket Hex	Complete Tool Part #	Head Assy #
7/32	R(R) - 22	RHA8200 - 22
1/4	R(R) - 25	RHA8200 - 25
9/32	R(R) - 28	RHA8200 - 28
5/16	R(R) - 31	RHA8200 - 31
11/32	R(R) - 34	RHA8200 - 34
3/8	R(R) - 37	RHA8200 - 37
7/16	R(R) - 43	RHA8200 - 43
9/32 thru hex	R(R) - 932	RHA8200 - 932

20° Offset Ratchet Head
With Flush or Extended Socket

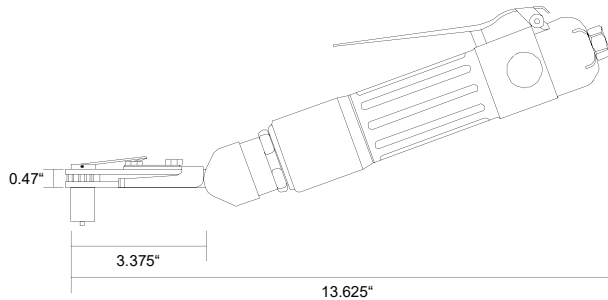

- To Order:
1. Determine the RPM required.
 2. Determine the required Socket Hex size.
 2. Determine the socket length and hex key size.

Example: QRA6 - 22 - 10 - 5

- 600 RPM motor.
- 7/32" socket.
- 1.0" extended socket with QRS® System.
- Including 1/16" hex tip.

(R) Motor RPM	Socket RPM	Socket Torque @ 90 PSI
4=400	45	360 in lbs
6=600	85	204 in lbs
10=1000	145	115 in lbs
15=1500	215	97 in lbs
20=2000	285	85 in lbs

(E) Socket Length
1 = flush
4 = 0.25"
5 = 0.50"
7 = 0.75"
10 = 1.0"
15 = 1.5"
20 = 2.0"
25 = 2.50"
30 = 3.0"

Hex Tip	Socket Hex	Complete Tool Part #	Head Assy #
1/16 QRK - 5	7/32	QRA(R) - 22 - (E) - 5	QR - 22 - (E) - 5
	1/4	QRA(R) - 25 - (E) - 5	QR - 25 - (E) - 5
	9/32	QRA(R) - 28 - (E) - 5	QR - 28 - (E) - 5
	5/16	QRA(R) - 31 - (E) - 5	QR - 31 - (E) - 5
5/64 QRK - 6	11/32	QRA(R) - 34 - (E) - 5	QR - 34 - (E) - 5
	7/32	QRA(R) - 22 - (E) - 6	QR - 22 - (E) - 6
	1/4	QRA(R) - 25 - (E) - 6	QR - 25 - (E) - 6
	9/32	QRA(R) - 28 - (E) - 6	QR - 28 - (E) - 6
3/32 QRK - 8	5/16	QRA(R) - 31 - (E) - 6	QR - 31 - (E) - 6
	11/32	QRA(R) - 34 - (E) - 6	QR - 34 - (E) - 6
	3/8	QRA(R) - 37 - (E) - 6	QR - 37 - (E) - 6
	5/16	QRA(R) - 31 - (E) - 8	QR - 31 - (E) - 8
7/16	11/32	QRA(R) - 34 - (E) - 8	QR - 34 - (E) - 8
	3/8	QRA(R) - 37 - (E) - 8	QR - 37 - (E) - 8
	7/16	QRA(R) - 43 - (E) - 8	QR - 43 - (E) - 8



Hi-Lok Nut Runner

LHL600 Series

(Stall Torque)

LOK-FAST



Ordering Information:

1. Select the *Head Offset* required (H)
2. Select the *Socket Hex Size*
3. Select the *Socket Length* required (x)
4. Select the *Hex Tip* required
5. Combine Part Numbers as Shown Below

Example: **LHL600 - 25D5**

LHL600 ----- Basic Tool
25 ---- 1/4" Socket Hex
D --- 1" Long Extended Socket
5 - 1/16" Hex Tip

X	Socket Length
D	1.0"
F	1.5"
H	2.0"
L	3.0"
P	4.0"

Tool Data	
Performance Rated @	90 PSI
Air Inlet	1/4 N.P.T.
RPM	850
Max Torque	55 in-lb

Hex Tip	Socket Hex	Complete Part #
1/16	7/32	LHL600 - 21(x)5
	1/4	LHL600 - 25(x)5
	9/32	LHL600 - 28(x)5
	5/16	LHL600 - 31(x)5
	11/32	LHL600 - 34(x)5
5/64	7/32	LHL600 - 21(x)6
	1/4	LHL600 - 25(x)6
	9/32	LHL600 - 28(x)6
	5/16	LHL600 - 31(x)6
	11/32	LHL600 - 34(x)6
3/32	3/8	LHL600 - 37(x)6
	5/16	LHL600 - 31(x)8
	11/32	LHL600 - 34(x)8
	7/16	LHL600 - 43(x)8



Hi-Lok Nut Runner

LHL700 Series

(Stall Torque)



Ordering Information:

1. Select the *Socket Hex Size*
2. Select the *Hex Tip* required
3. Combine Part Numbers as Shown Below

Example: **LHL700 - 25D5**

LHL700 ----- Basic Tool
25 ----- 1/4" Socket Hex
5 ----- 1/16" Hex Tip

X	Socket Length
D	1.0"

Hex Tip	Socket Hex	Complete Part #
1/16	7/32	LHL700 - 21(D)5
	1/4	LHL700 - 25(D)5
	9/32	LHL700 - 28(D)5
	5/16	LHL700 - 31(D)5
	11/32	LHL700 - 34(D)5
5/64	7/32	LHL700 - 21(D)6
	1/4	LHL700 - 25(D)6
	9/32	LHL700 - 28(D)6
	5/16	LHL700 - 31(D)6
	11/32	LHL700 - 34(D)6
3/32	3/8	LHL700 - 37(D)6
	5/16	LHL700 - 31(D)8
	11/32	LHL700 - 34(D)8
	3/8	LHL700 - 37(D)8
	7/16	LHL700 - 43(D)8

Tool Data	
Performance Rated @	90 PSI
Air Inlet	1/4 N.P.T.
RPM	850
Max Torque	55 in-lb



Ratchet Hand Tools

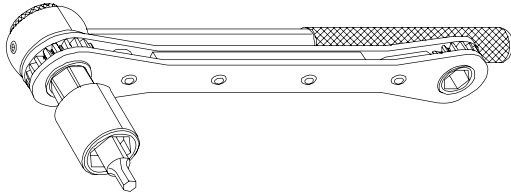

(E) Socket Length
1 = flush
4 = 0.25"
5 = 0.50"
7 = 0.75"
10 = 1.0"
15 = 1.5"
20 = 2.0"
25 = 2.50"
30 = 3.0"

To Order:

1. Determine the socket hex and the socket length.
2. Determine the size of the hex key.

Example: **QHRA - 22 - 10 - 5**

- 7/32" socket.
- 1.0" extended socket with QRS[®] System.
- Including 1/16" hex tip

Hex Tip	Socket Hex	Complete Part #
1/16 QRK - 5	7/32	QHRA - 22 - (E) - 5
	1/4	QHRA - 25 - (E) - 5
	9/32	QHRA - 28 - (E) - 5
	5/16	QHRA - 31 - (E) - 5
5/64 QRK - 6	11/32	QHRA - 34 - (E) - 5
	7/32	QHRA - 22 - (E) - 6
	1/4	QHRA - 25 - (E) - 6
	9/32	QHRA - 28 - (E) - 6
	5/16	QHRA - 31 - (E) - 6
3/8 QRK - 8	11/32	QHRA - 34 - (E) - 6
	3/8	QHRA - 37 - (E) - 6
	5/16	QHRA - 31 - (E) - 8
	11/32	QHRA - 34 - (E) - 8
3/8 QRK - 8	3/8	QHRA - 37 - (E) - 8
	7/16	QHRA - 43 - (E) - 8

Glossary for QRS[®] Systems

20° or 90° Geared Angle Head: An offset internal gear driven unit in which driving torque is transmitted to hex gear or socket accessory assemblies held at angles of 20 or 90 degrees to the axis of the motor spindle.

20° or 90° Offset Angle Head Ratchet: Rotational torque of the air motor is converted into pulses through an internal cam which transmits the torque via the pawl to the drive gear which may be configured flush or with extended socket accessory assemblies to drive frangible collars at an angle of 20 or 90 degrees to the axis of the motor spindle.

Back Drive: The socket and other accessory assemblies are attached on the opposite side of the geared head for limited access applications. The rotation of the motor must be opposite to that of the conventional side for identical gear trains. This is not an option for offset ratchet drivers.

Collar: The body component of a frangible type threaded fastener which remains on the threaded pin after the hex drive has been sheared off.

Drive Gear: The terminal gear of a geared head which is configured either to accept the hex shank of an extended socket or which has a flush hex configuration for transmitting torque to the frangible collar.

Extended Socket: A socket designed to fit into a drive gear at one end and at the opposite end having a recessed hex dimensioned to accept the hex drive of a frangible collar for transmitting torque for tightening onto a mating pin until sheared off.

Extended Socket Accessory Assembly: Adapter assembly which consists of an extended socket and hex tip holder and a hex tip as well as other necessary components required to attach the assembly driver as a complete unit for installation of frangible collars.

Extended Socket Assembly: Adapter assembly consisting of the extended socket and retaining ring supplied as a unit to be used with an extended hex holder assembly on an angle driver.

Frangible (Torque-Off) Collar: A threaded collar in which the hex wrenching portion is sheared off from its body, the collar remaining on the threaded pin after torque-off. Torque control is controlled by the engineering of the collar.



LOK-FAST

Glossary for QRS® Systems

Flush Gear: Terminal drive gear which has a recessed hex on the drive side to engage the hex portion of the collar in a close quarter application not requiring an extended socket.

Flush Tool: Complete assembly driver which is designed for close quarter applications without use of extended socket.

Hex Holder: The assembly component of a socket accessory assembly which is held stationary within the drive gear and through the socket or drive gear. It is used to hold the hex wrench tip stationary during installation.

Hex Holder Assembly: The hex holder and hex wrench tip supplied as an assembly unit for use with a socket or drive gear for installation of frangible collars.

Hex Recess: The hexagon wrench cavity at the threaded end of the pin which accepts the hex wrench tip. The hex recess allows the wrench tip to keep the pin stationary during installation.

Hex Wrench Tip: The wrench which is held stationary by the hex tip holder. This fits into the hex recess of the pin and keeps it stationary during installation.

Interference Fit Hole: A hole prepared in material that is slightly smaller than the shank diameter of the pin. This prevents the pin from spinning during installation and negates the need for hex tips.

Matched Hex Pairs: Dimensions for sockets and hex wrench tips, the larger of which refers to the hex drive dimensions of the collar, and the smaller of which refers to the hex recess dimensions in the threaded end of the pin into which the hex wrench tip is inserted during installation.

Non-Interference Fit Holes: A hole prepared in material with a slightly larger diameter than that of the pin which allows the pin to rotate during installation, therefore needing the use of hex tips during installation.

Non Torque-Control Tool: Installation tool which does not contain a clutch or other torque-control device to control the torque output.

Offset Handle: Grip portion of a pistol type pneumatic motor which extends approximately at a 90 degree angle to the axis of rotation of the motor spindle.

Quick Release System (QRS™): Hex tip holder which the hex holder holds the hex tip by means of a retaining shaft which allows for quick and easy replacement of the hex tip. Eliminates the need for external tools to replace the hex tip. Used in non-interference fit holes.

Ratchet Gear: Single drive gear used only on ratchet heads. Same application as drive gear in a geared head tool, except ratchet gears cannot be used in back drive applications.

Retention Shaft: A small shaft which is threaded at one end and retains the hex tip in the holder, and when rotated pulls or pushes the hex tip in or out.

RPM of Tool: The rotation speed of the motor spindle measured at the gear case outlet.

Socket: See extended socket definition.

Torque: Rotation force measured in inch pounds either at the spindle shaft or the drive gear, depending upon the specification.

ZEPHYR[®]
T O O L
G R O U P



TOOLS ENGINEERED TO PERFORM

ZEPHYR[®]
SCREWDRIVING TOOLS

KWIK-LOK[™]
TEMPORARY FASTENERS

ZEPHYR[®]
AEROSPACE HAND & PNEUMATIC TOOLS

LOK-FAST[™]
AEROSPACE FASTENER TOOLS

Martin[™]
AIRCRAFT TOOL

LOK-FAST

Quick Change System[™] Hi-Lok[®] Type Fastener Installation Tools

ZEPHYR TOOL GROUP

201 Hindry Avenue

Los Angeles, CA 90301

Tel. 310-410-4907 ■ Email: sales@zephyrtoolgroup.com ■ zephyrtoolgroup.com

Page 15

11/15/18



Quick Change System[®]

LOK-FAST

The **Quick Change System** was designed to save time when changing from one size tool to another , or when changing from installation to removal of fasteners. This system was also designed to be used with existing Hi-Lok[®] tooling purchased as complete, ready to use assemblies.

Lok-Fast offers the quick change installation sockets in all the standard hex sizes used with our current Hi-Lok[®] tooling, and removal sockets to remove the full range of fasteners.

Removal

The illustration below shows the shoulder diameter that dictates the grip range referred to in the following pages

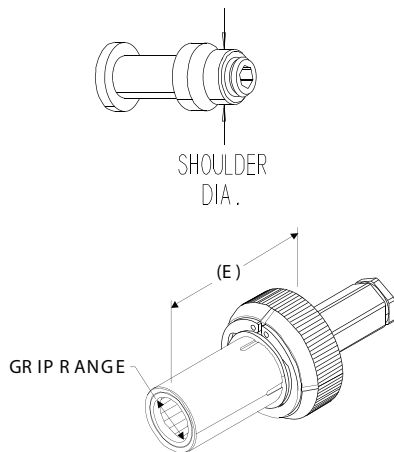

Installation

The illustration below shows the socket hex size referred to in the following pages.

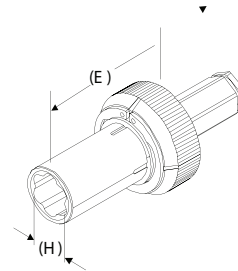



Quick Change Removal Socket

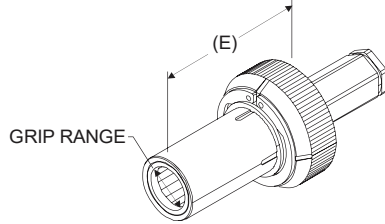

To Order:

1. Determine the grip size needed.
2. Select the size of the hex tip.

Example: QCRA235 - 10 - 6

- 1" long socket with grip range 0.235 - 0.245.
- 5/64" hex tip.

(H) Hex Tip
5 = 1/16
6 = 5/64
8 = 3/32
10 = 1/8

Complete Assembly	Removal Socket	Grip Range
QCRA235 - (E) - (H)	QCHR235 - (E)	0.235 - 0.255
QCRA245 - (E) - (H)	QCHR245 - (E)	0.245 - 0.265
QCRA255 - (E) - (H)	QCHR255 - (E)	0.255 - 0.275
QCRA265 - (E) - (H)	QCHR265 - (E)	0.265 - 0.285
QCRA275 - (E) - (H)	QCHR275 - (E)	0.275 - 0.305
QCRA295 - (E) - (H)	QCHR295 - (E)	0.295 - 0.315
QCRA305 - (E) - (H)	QCHR305 - (E)	0.305 - 0.325
QCRA315 - (E) - (H)	QCHR315 - (E)	0.315 - 0.335
QCRA325 - (E) - (H)	QCHR325 - (E)	0.325 - 0.345
QCRA335 - (E) - (H)	QCHR335 - (E)	0.335 - 0.355
QCRA355 - (E) - (H)	QCHR355 - (E)	0.355 - 0.375
QCRA375 - (E) - (H)	QCHR375 - (E)	0.375 - 0.395
QCRA395 - (E) - (H)	QCHR395 - (E)	0.395 - 0.415
QCRA415 - (E) - (H)	QCHR415 - (E)	0.415 - 0.435
QCRA435 - (E) - (H)	QCHR435 - (E)	0.435 - 0.455

QCRSS23 - 43 Complete Removal Socket Set
Includes Four Hex Tips
Does not Include Holder Accessories

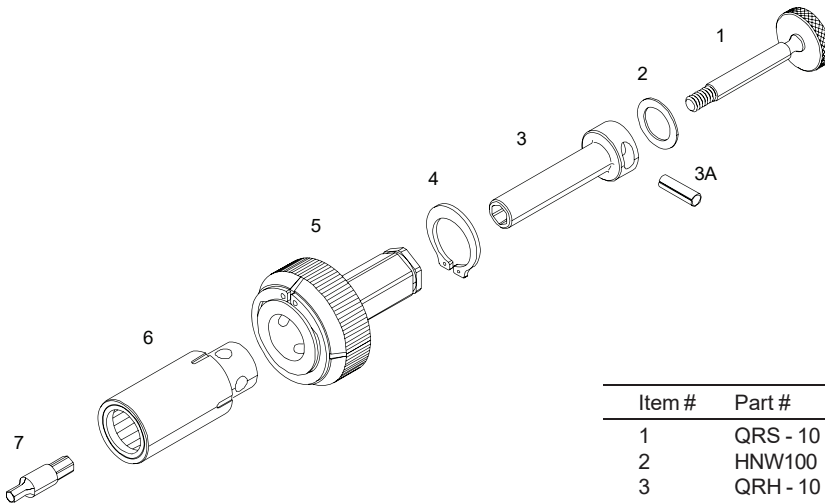

Item #	Part #	Description
1	QRS - 10	Retention Shaft
2	HNW100	Nylon Washer
3	QRH - 10	Holder
3A	ZT663-10	For Hand Tools Only
4	HRC100	Retaining Clip
5	QCR - 281	Quick Change Recepticle
6	QCHR(R) - 10	Quick Change Removal Socket
7	QRK - (H)	Hex Tip



Quick Change Installation Socket

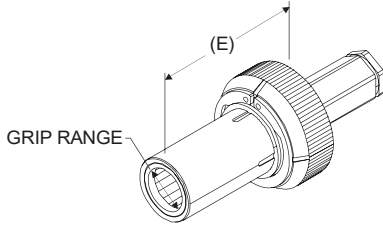

To Order:

1. Determine the fastener hex and pin recess size.
2. Determine the socket length required.

Example: QCA250 - 10 - 6

- 1" long socket with 1/4" socket.
- 5/64" hex tip.

(E)	(H)
Socket Length	Hex Tip
10 = 1.00"	5 = 1/16
15 = 1.50"	6 = 5/64
20 = 2.00"	8 = 3/32
25 = 2.50"	10 = 1/8
30 = 3.00"	

Socket Hex	Complete Assembly	Installation Socket	Holder	Retention Shaft
7/32	QCA218 - (E) - (H)	QCHS218 - (E)		
1/4	QCA250 - (E) - (H)	QCHS250 - (E)		
9/32	QCA281 - (E) - (H)	QCHS281 - (E)		
5/16	QCA312 - (E) - (H)	QCHS312 - (E)	QRH - (E)	QRS - (E)
11/32	QCA343 - (E) - (H)	QCHS343 - (E)		
3/8	QCA375 - (E) - (H)	QCHS375 - (E)		
7/16	QCA437 - (E) - (H)	QCHS437 - (E)		
QCSS23 - 43 - (E)	Complete Installation Socket Set Includes Four Hex Tips Does not Include Holder Accessories			

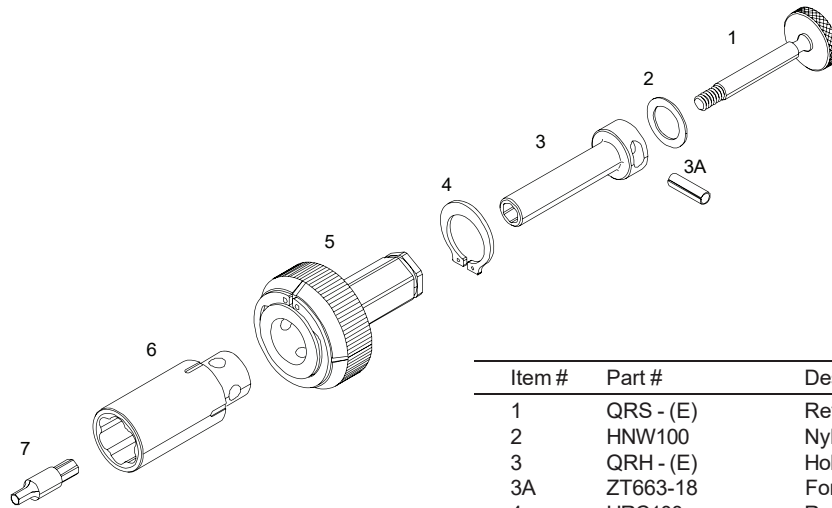

Item #	Part #	Description
1	QRS - (E)	Retention Shaft
2	HNW100	Nylon Washer
3	QRH - (E)	Holder
3A	ZT663-18	For Hand Tools Only
4	HRC100	Retaining Clip
5	QCR - 281	Quick Change Recepticle
6	QCHS(XXX) - (E)	Quick Change Installation Socket
7	QRK - (H)	Hex Tip



Quick Change Hand Installation Tool

LOK-FAST

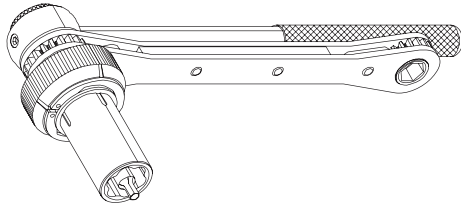

To Order:

1. Determine the fastener hex and pin recess size.
2. Determine the socket length required.

Example: QCHA218 - 10 - 6

- 1" long socket with 7/32" hex.
- 5/64" hex tip.

(E) Socket Length	(H) Hex Tip
10 = 1.00"	- 5 = 1/16
20 = 2.00"	- 6 = 5/64
30 = 3.00"	- 8 = 3/32
	- 10 = 1/8

Socket Hex	Complete Tool Assy
7/32	QCHA218 - (E) - (H)
1/4	QCHA250 - (E) - (H)
9/32	QCHA281 - (E) - (H)
5/16	QCHA312 - (E) - (H)
11/32	QCHA343 - (E) - (H)
3/8	QCHA375 - (E) - (H)
7/16	QCHA437 - (E) - (H)

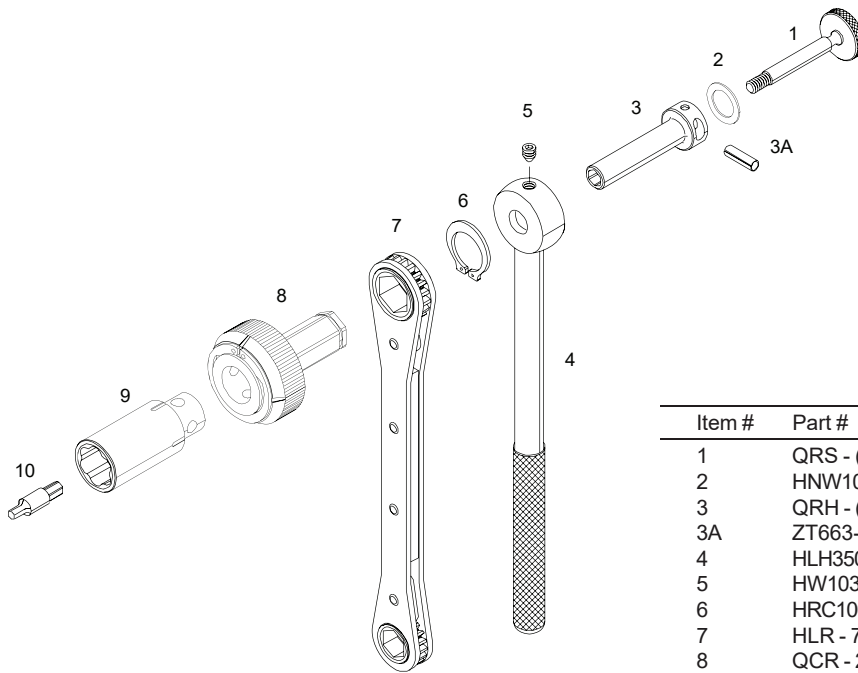

Item #	Part #	Description
1	QRS - (E)	Retention Shaft
2	HNW100	Nylon Washer
3	QRH - (E)	Holder
3A	ZT663-18	For Hand Tools Only
4	HLH350	Handle
5	HW103	Set Screw
6	HRC100	Retaining Clip
7	HLR - 7	Ratchet Wrench
8	QCR - 281	Quick Change Receptacle
9	QCHS(XXX) - (E)	Quick Change Installation Socket
10	QRK - (H)	Hex Tip



LOK-FAST

Quick Change Hand Removal Tool

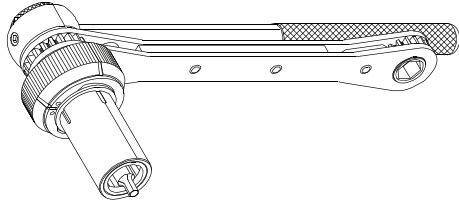

To Order:

1. Determine the fastener hex and pin recess size.
2. Determine the socket length required.

Example: QCHRA255 - 10 - 8

- 1" long socket with grip range of 0.235 - 0.255
- 3/32" hex tip.

(H)
Hex Tip
5 = 1/16
6 = 5/64
8 = 3/32
10 = 1/8

Complete Assembly	Removal Socket	Grip Range
QCHRA235 - (10) - (H)	QCHR235 - (10)	0.235 - 0.255
QCHRA245 - (10) - (H)	QCHR245 - (10)	0.245 - 0.265
QCHRA255 - (10) - (H)	QCHR255 - (10)	0.255 - 0.275
QCHRA265 - (10) - (H)	QCHR265 - (10)	0.265 - 0.285
QCHRA275 - (10) - (H)	QCHR275 - (10)	0.275 - 0.295
QCHRA285 - (10) - (H)	QCHR285 - (10)	0.285 - 0.305
QCHRA295 - (10) - (H)	QCHR295 - (10)	0.295 - 0.315
QCHRA305 - (10) - (H)	QCHR305 - (10)	0.305 - 0.325
QCHRA315 - (10) - (H)	QCHR315 - (10)	0.315 - 0.335
QCHRA325 - (10) - (H)	QCHR325 - (10)	0.325 - 0.345
QCHRA335 - (10) - (H)	QCHR335 - (10)	0.335 - 0.355
QCHRA355 - (10) - (H)	QCHR355 - (10)	0.355 - 0.375
QCHRA375 - (10) - (H)	QCHR375 - (10)	0.375 - 0.395
QCHRA395 - (10) - (H)	QCHR395 - (10)	0.395 - 0.415
QCHRA415 - (10) - (H)	QCHR415 - (10)	0.415 - 0.435
QCHRA435 - (10) - (H)	QCHR435 - (10)	0.435 - 0.455

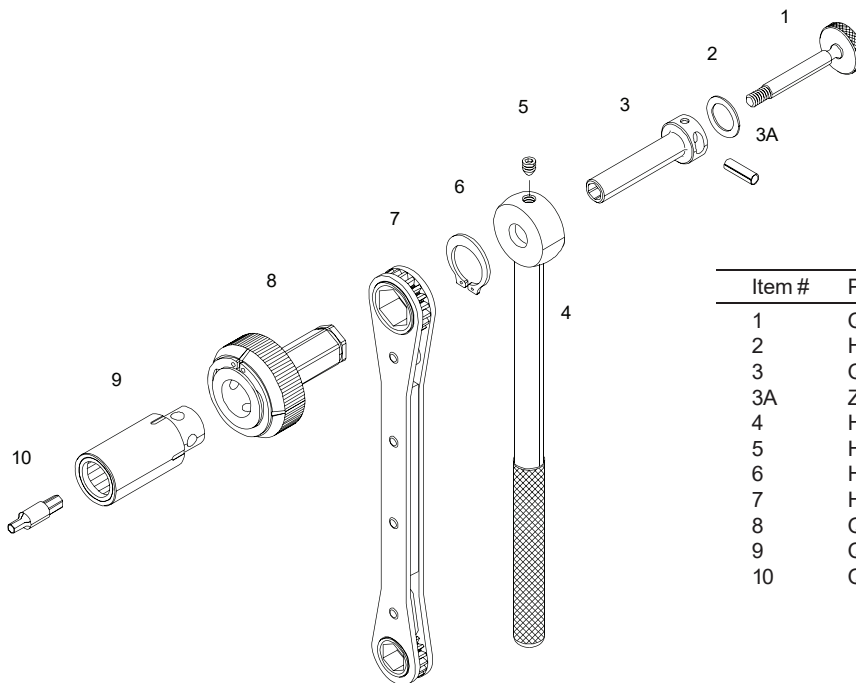

Item #	Part #	Description
1	QRS - (E)	Retention Shaft
2	HNW100	Nylon Washer
3	QRH - (E)	Holder
3A	ZT663-18	For Hand Tools Only
4	HLH350	Handle
5	HW103	Set Screw
6	HRC100	Retaining Clip
7	HLR - 7	Ratchet Wrench
8	QCR - 281	Quick Change Receptacle
9	QCHR(R) - (E)	Quick Change Installation Socket
10	QRK - (H)	Hex Tip



HI-LOK PLIERS - ZHP SERIES ZHP-100 & ZHP-200

LOK-FAST



ZEPHYR's Removal Pliers offer a quick and inexpensive alternative for removing larger size frangible hex collars such as Hi-Lok, Hi-Lite, Hi-Tigue, Veri-Lite and C-Lok fasteners. The hardened steel jaws are specially designed to maximize the gripping surface around the collar.

ZHP-100 (7 3/8" OAL) hot forged Hi-Lok collar removal pliers for sizes 5/32", 3/16", 1/4" and 5/16".

ZHP-200 (9" OAL) hot forged Hi-Lok collar removal pliers for sizes 5/16", 5/8", 3/4" fasteners.



QCK-4000

LOK-FAST

PNEUMATIC AND HAND TOOL INSTALLATION AND REMOVAL KIT

INSTRUCTIONS

1. Pneumatic and Hand Tool Installation:
Determine the fastener hex and pin recess size.
2. Pneumatic and Hand tool Removal:
Determine the grip size needed.
Select the size of the hex tip.
3. For socket replacement rotate lock ring
in opposite direction of tool rotation to lock socket.

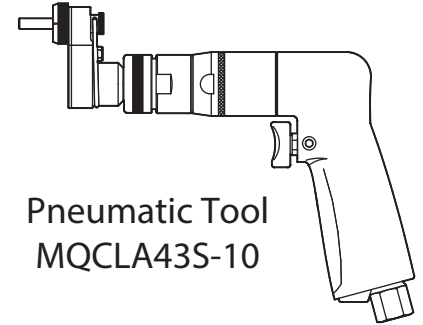
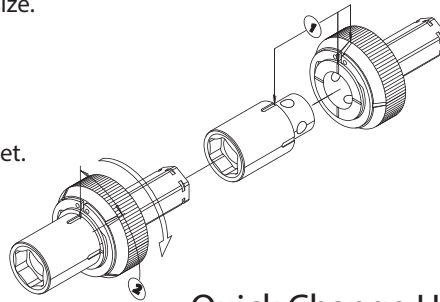

Pneumatic Tool
MQCLA43S-10

Quick Change Hand Installation Tool

Quick Change Hand Removal Tool

INSTALLATION
TOOL
QCHA932

REMOVAL
TOOL
QCHRA932

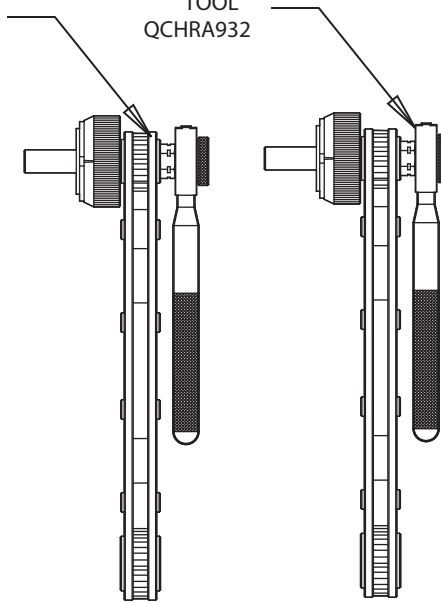

QCHS437-10

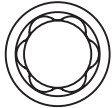

QCHS375-10



QCHS343-10



QCHS312-10

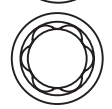

QCHS281-10

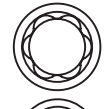

QCHS250-10

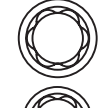

QCHS218-10

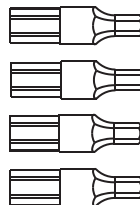

QRK-5 (QTY-2)

QRK-6 (QTY-2)

QRK-8 (QTY-2)

QRK-10 (QTY-2)

QCHR235-10
RANGE: .235-.255



QCHR245-10
RANGE: .245-.265



QCHR255-10
RANGE: .255-.275



QCHR265-10
RANGE: .265-.285



QCHR275-10
RANGE: .275-.295



QCHR285-10
RANGE: .285-.305



QCHR295-10
RANGE: .295-.315



QCHR305-10
RANGE: .305-.325



QCHR315-10
RANGE: .315-.335



QCHR325-10
RANGE: .325-.345



QCHR335-10
RANGE: .335-.355



QCHR355-10
RANGE: .355-.375



QCHR375-10
RANGE: .375-.395



QCHR395-10
RANGE: .395-.415





QCK-4010

LOK-FAST

PNEUMATIC INSTALLATION AND REMOVAL KIT

INSTRUCTIONS

1. Pneumatic Tool Installation:
Determine the fastener hex and pin recess size.
2. Pneumatic Removal:
Determine the grip size needed.
Select the size of the hex tip.
3. For socket replacement rotate lock ring
in opposite direction of tool rotation to lock socket.

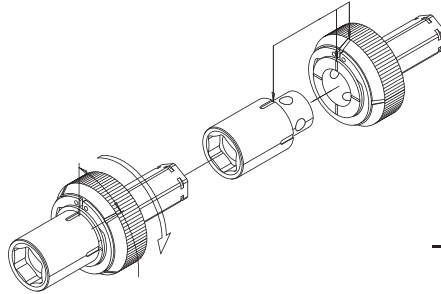

Installation Sockets

QCHS437-10 7/16	
QCHS375-10 3/8	
QCHS343-10 11/32	
QCHS312-10 5/16	
QCHS281-10 9/32	
QCHS250-10 1/4	
QCHS218-10 7/32	

Pneumatic Tool MQCLA43S-10

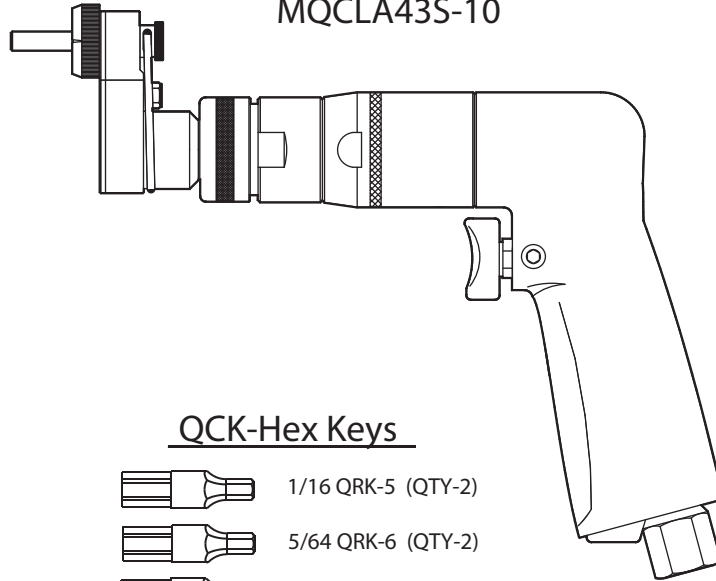

QCK-Hex Keys

	1/16 QRK-5 (QTY-2)
	5/64 QRK-6 (QTY-2)
	3/32 QRK-8 (QTY-2)
	1/8 QRK-10 (QTY-2)

Removal Sockets

QCHR235-10 RANGE: .235-.255	
QCHR245-10 RANGE: .245-.265	
QCHR255-10 RANGE: .255-.275	
QCHR265-10 RANGE: .265-.285	
QCHR275-10 RANGE: .275-.295	
QCHR285-10 RANGE: .285-.305	
QCHR295-10 RANGE: .295-.315	
QCHR305-10 RANGE: .305-.325	
QCHR315-10 RANGE: .315-.335	
QCHR325-10 RANGE: .325-.345	
QCHR335-10 RANGE: .335-.355	
QCHR355-10 RANGE: .355-.375	
QCHR375-10 RANGE: .375-.395	
QCHR395-10 RANGE: .395-.415	



QCK-4020

PNEUMATIC INSTALLATION KIT

LOK-FAST

INSTRUCTIONS

1. Pneumatic Tool Installation:
Determine the fastener hex and pin recess size.
2. For socket replacement rotate lock ring
in opposite direction of tool rotation to lock socket.

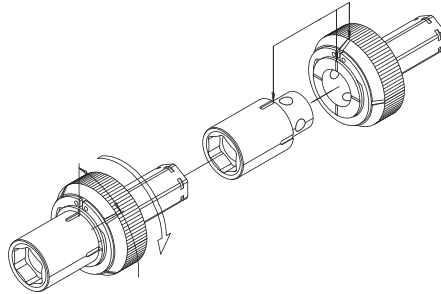

Installation Sockets

QCHS437-10 7/16	
QCHS375-10 3/8	
QCHS343-10 11/32	
QCHS312-10 5/16	
QCHS281-10 9/32	
QCHS250-10 1/4	
QCHS218-10 7/32	

Pneumatic Tool
MQCLA43S-10

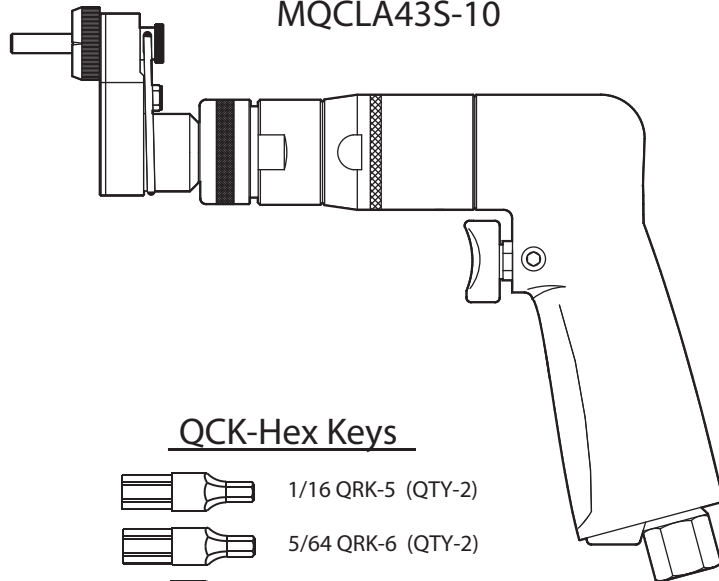

QCK-Hex Keys

	1/16 QRK-5 (QTY-2)
	5/64 QRK-6 (QTY-2)
	3/32 QRK-8 (QTY-2)
	1/8 QRK-10 (QTY-2)



QCK-4030

LOK-FAST

PNEUMATIC REMOVAL KIT

INSTRUCTIONS

1. Pneumatic Removal:

Determine the grip size needed.







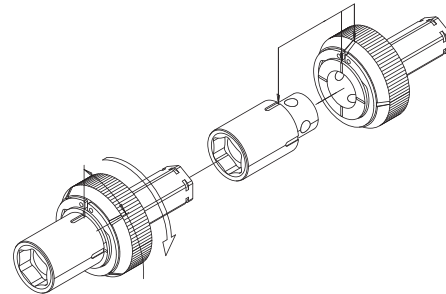







Select the size of the hex tip.

2. For socket replacement rotate lock ring

in opposite direction of tool rotation to lock socket.





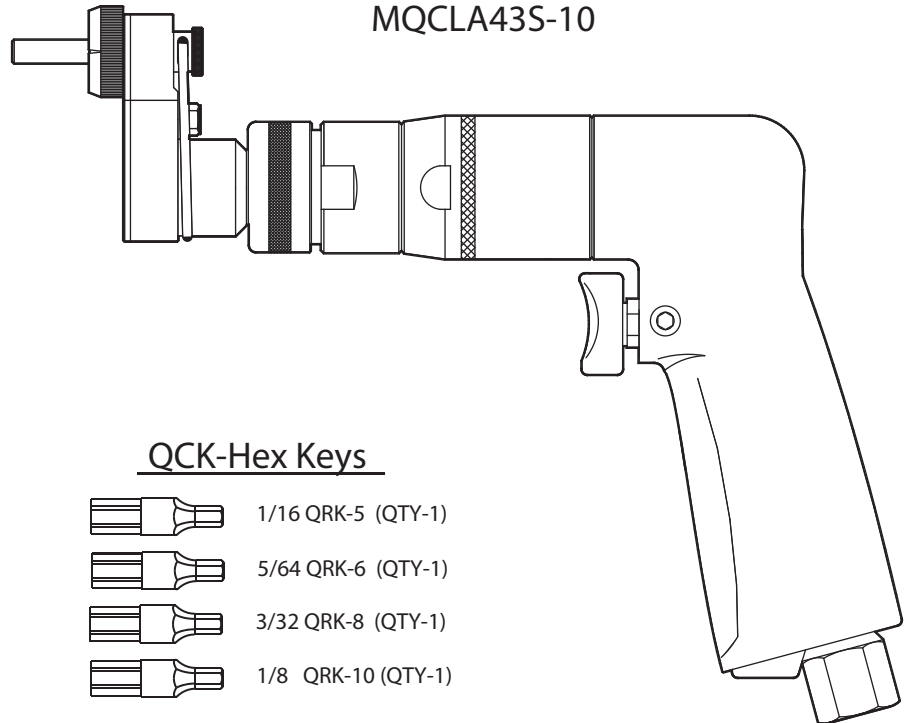

Removal Sockets

QCHR235-10	
RANGE:.235-.255	
QCHR245-10	
RANGE:.245-.265	
QCHR255-10	
RANGE:.255-.275	
QCHR265-10	
RANGE:.265-.285	
QCHR275-10	
RANGE:.275-.295	
QCHR285-10	
RANGE:.285-.305	
QCHR295-10	
RANGE:.295-.315	
QCHR305-10	
RANGE:.305-.325	
QCHR315-10	
RANGE:.315-.335	
QCHR325-10	
RANGE:.325-.345	
QCHR335-10	
RANGE:.335-.355	
QCHR355-10	
RANGE:.355-.375	
QCHR375-10	
RANGE:.375-.395	
QCHR395-10	
RANGE:.395-.415	

Pneumatic Tool
MQCLA435-10



QCK-Hex Keys

	1/16 QRK-5 (QTY-1)
	5/64 QRK-6 (QTY-1)
	3/32 QRK-8 (QTY-1)
	1/8 QRK-10 (QTY-1)



QCK-4040

LOK-FAST

HAND TOOL INSTALLATION AND REMOVAL KIT

INSTRUCTIONS

1. Hand Tool Installation:
Determine the fastener hex and pin recess size.
2. Hand tool Removal:
Determine the grip size needed.
Select the size of the hex tip.
3. For socket replacement rotate lock ring
in opposite direction of tool rotation to lock socket.

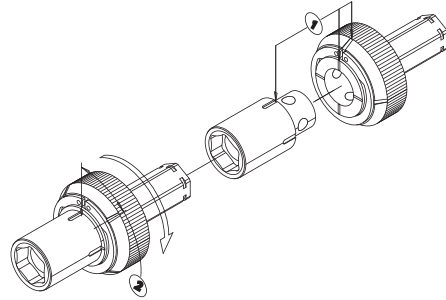

Quick Change Hand Installation Tool

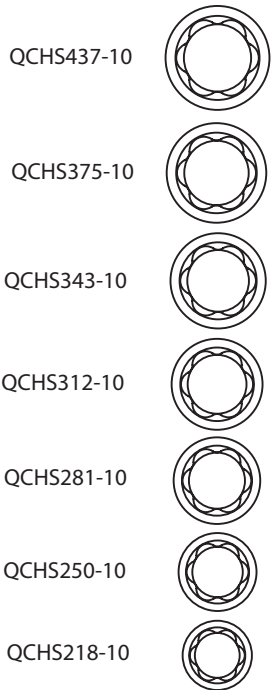

INSTALLATION
TOOL
QCHA932

Quick Change Hand Removal Tool

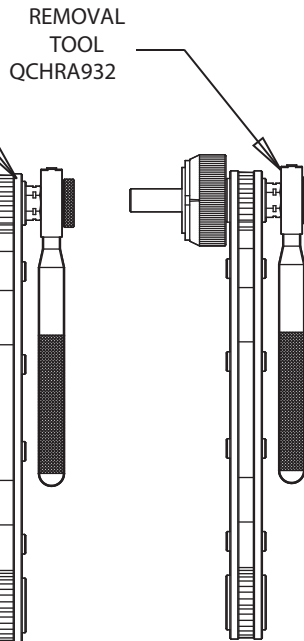

REMOVAL
TOOL
QCHRA932

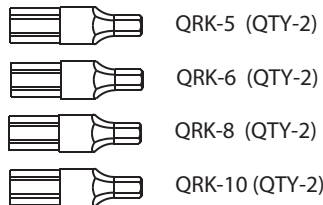

QCHR235-10
RANGE: 235-255

QCHR245-10
RANGE: 245-265

QCHR255-10
RANGE: 255-275

QCHR265-10
RANGE: 265-285

QCHR275-10
RANGE: 275-295

QCHR285-10
RANGE: 285-305

QCHR295-10
RANGE: 295-315

QCHR305-10
RANGE: 305-325

QCHR315-10
RANGE: 315-335

QCHR325-10
RANGE: 325-345

QCHR335-10
RANGE: 335-355

QCHR355-10
RANGE: 355-375

QCHR375-10
RANGE: 375-395

QCHR395-10
RANGE: 395-415





QCK-4050

HAND INSTALLATION KIT

LOK-FAST

INSTRUCTIONS

1. Hand Tool Installation:
Determine the fastener hex and pin recess size.
2. For socket replacement rotate lock ring
in opposite direction of tool rotation to lock socket.

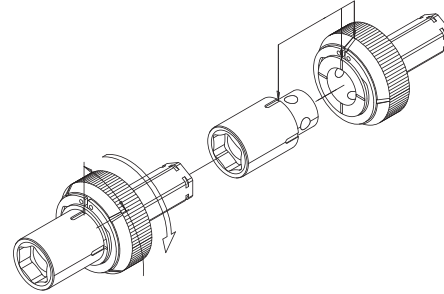

Quick Change Hand Installation Tool

Installation Sockets

QCHS437-10
7/16

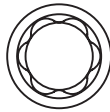

QCHS375-10
3/8



QCHS343-10
11/32

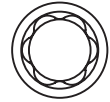

QCHS312-10
5/16

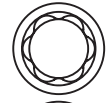

QCHS281-10
9/32

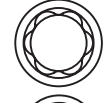

QCHS250-10
1/4

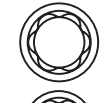

QCHS218-10
7/32



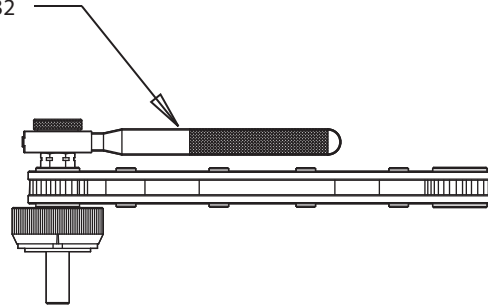

INSTALLATION
TOOL
QCHA932



QCK-Hex Keys

 1/16 QRK-5 (QTY-1)

 5/64 QRK-6 (QTY-1)

 3/32 QRK-8 (QTY-1)

 1/8 QRK-10 (QTY-1)



QCK-4060

HAND REMOVAL KIT

LOK-FAST

INSTRUCTIONS

1. Hand tool Removal:
 - Determine the grip size needed.
 - Select the size of the hex tip.
2. For socket replacement rotate lock ring in opposite direction of tool rotation to lock socket.

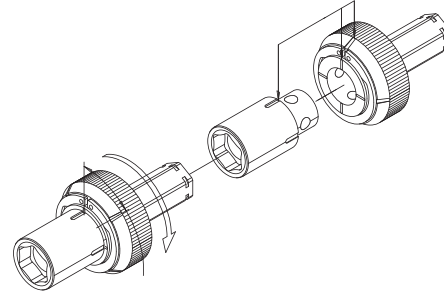

Removal Sockets

QCHR235-10 RANGE:.235-.255	
QCHR245-10 RANGE:.245-.265	
QCHR255-10 RANGE:.255-.275	
QCHR265-10 RANGE:.265-.285	
QCHR275-10 RANGE:.275-.295	
QCHR285-10 RANGE:.285-.305	
QCHR295-10 RANGE:.295-.315	
QCHR305-10 RANGE:.305-.325	
QCHR315-10 RANGE:.315-.335	
QCHR325-10 RANGE:.325-.345	
QCHR335-10 RANGE:.335-.355	
QCHR355-10 RANGE:.355-.375	
QCHR375-10 RANGE:.375-.395	
QCHR395-10 RANGE:.395-.415	

Quick Change Hand Removal Tool

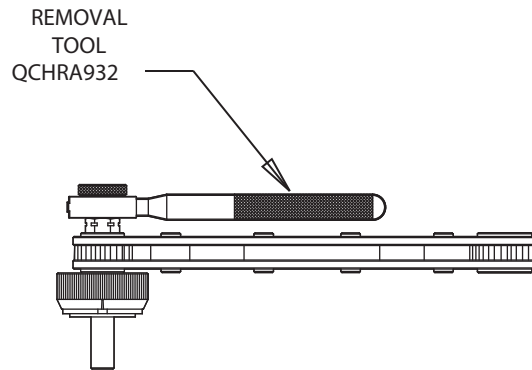

QCK-Hex Keys

	1/16 QRK-5 (QTY-1)
	5/64 QRK-6 (QTY-1)
	3/32 QRK-8 (QTY-1)
	1/8 QRK-10 (QTY-1)



QCK-4070

LOK-FAST

PNEUMATIC AND HAND TOOL INSTALLATION AND REMOVAL KIT

INSTRUCTIONS

1. Pneumatic and Hand Tool Installation:
Determine the fastener hex and pin recess size.
2. Pneumatic and Hand tool Removal:
Determine the grip size needed.
Select the size of the hex tip.
3. For socket replacement rotate lock ring
in opposite direction of tool rotation to lock socket.

Quick Change Hand Installation Tool

Installation Sockets

QCHS437-10
7/16



QCHS375-10
3/8



QCHS343-10
11/32

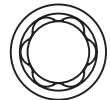

QCHS312-10
5/16



QCHS281-10
9/32

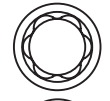

QCHS250-10
1/4

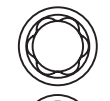

QCHS218-10
7/32



4 Gears
"L" Head Assy
MLH4-932-S

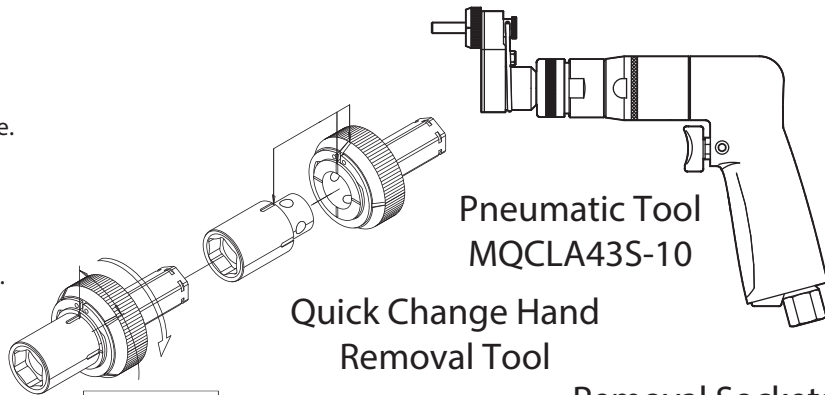

Pneumatic Tool
MQCLA43S-10

Quick Change Hand
Removal Tool

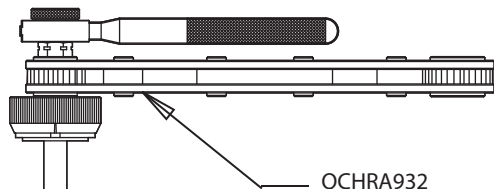

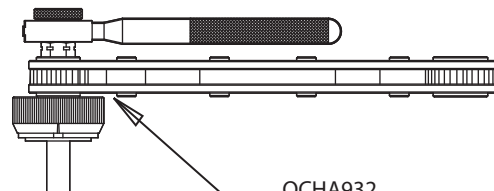

QCHRA932

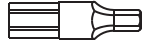

QCHA932

QCK-Hex Keys

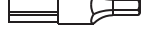
-  1/16 QRK-5 (QTY-2)
-  5/64 QRK-6 (QTY-2)
-  3/32 QRK-8 (QTY-2)
-  1/8 QRK-10 (QTY-2)

Removal Sockets

QCHR235-10
RANGE: .235-.255



QCHR245-10
RANGE: .245-.265



QCHR255-10
RANGE: .255-.275



QCHR265-10
RANGE: .265-.285



QCHR275-10
RANGE: .275-.295



QCHR285-10
RANGE: .285-.305



QCHR295-10
RANGE: .295-.315



QCHR305-10
RANGE: .305-.325



QCHR315-10
RANGE: .315-.335



QCHR325-10
RANGE: .325-.345



QCHR335-10
RANGE: .335-.355



QCHR355-10
RANGE: .355-.375



QCHR375-10
RANGE: .375-.395



QCHR395-10
RANGE: .395-.415





QCRSS23-43

LOK-FAST

COMPLET REMOVAL SOCKET SET

INSTRUCTIONS

1. Pneumatic and Hand tool Removal:
Determine the grip size needed.
Select the size of the hex tip.

Removal Sockets

QCHR235-10
RANGE: .235-.255



QCHR245-10
RANGE: .245-.265



QCHR255-10
RANGE: .255-.275



QCHR265-10
RANGE: .265-.285



QCHR275-10
RANGE: .275-.295



QCHR285-10
RANGE: .285-.305



QCHR295-10
RANGE: .295-.315



QCHR305-10
RANGE: .305-.325



QCHR315-10
RANGE: .315-.335



QCHR325-10
RANGE: .325-.345



QCHR335-10
RANGE: .335-.355



QCHR355-10
RANGE: .355-.375



QCHR375-10
RANGE: .375-.395



QCHR395-10
RANGE: .395-.415



QCK-Hex Keys



1/16 QRK-5 (QTY-1)



5/64 QRK-6 (QTY-1)



3/32 QRK-8 (QTY-1)



1/8 QRK-10 (QTY-1)



QCSS22-43

LOK-FAST

COMPLETE INSTALLATION SOCKET SET

INSTRUCTIONS

1. Pneumatic and Hand tool Installation:
Determine the hex size needed.
Select the size of the hex tip.

Installation Sockets

QCHS437-10 7/16	
QCHS375-10 3/8	
QCHS343-10 11/32	
QCHS312-10 5/16	
QCHS281-10 9/32	
QCHS250-10 1/4	
QCHS218-10 7/32	

QCK-Hex Keys

	1/16 QRK-5 (QTY-1)
	5/64 QRK-6 (QTY-1)
	3/32 QRK-8 (QTY-1)
	1/8 QRK-10 (QTY-1)



8105-H Ratchet Reaction Bracket



NEW

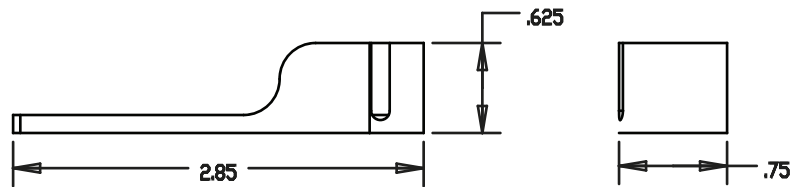
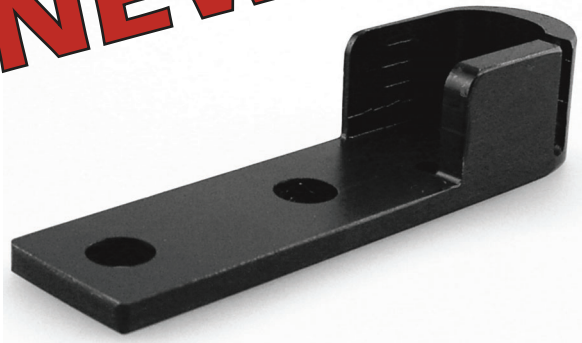

HI-LOK RATCHET SPRING SAVER REACTION BRACKET

With the use of today's modern composite materials, the aircraft industry faces new problems with the installation of frangible-collar type fasteners. These fasteners have, historically, had the benefit of interference fit holes. The loss of this benefit has created new challenges for installation tooling, resulting in excess hex key breakage, and coiling of hex key tension springs. Zephyr's new reaction bracket is designed to fit Zephyr series QSRA straight ratchet and series QRA 20° offset ratchet installation tools. Broken hex keys are easily replaced using Zephyr's QSA® (Quick-Release System). The entire system eliminates costly down time and removes the need to return the tool to the tool crib to replace a broken hex key or coiled spring.

ALSO AVAILABLE UPGRADE KIT: 8105-KIT FOR CURRENT TOOLS IN SERVICE



ZRWA
Reversible Ratchet Wrench Assembly

LOK-FAST



ZATHR250

ZATHR375

Zephyr's Ratchet Wrench Assemblies are ideal for the installation of any frangible hex collar fastener system such as Hi-Lok, Hi-Lite, Hi-Tigue, Veri-Lite and C-Lok. The ZATHR series ratchet has 72 teeth offering minimum handle swing for close quarter applications. The assembly consists of a 1/4" or 3/8" square drive reversible ratchet wrench with a through hole, a socket with a set screw and hex key with either a plastic screwdriver handle or a "T" handle. All the components listed below are completely interchangeable and can be ordered as an assembly or separately.

How to select a tool: From the parts list below determine the ratchet wrench 1/4" or 3/8" square drive, then select the appropriate socket hex and the hex key sizes that match the fastener pin and collar. Example:
ZRWA25-37-6 Includes:
ZATHR250 1/4" SQ Drive Ratchet Wrench
ZRWS25-37 3/8" Drive Hex Socket
ZRWK-6 5/64" Hex Key with Handle

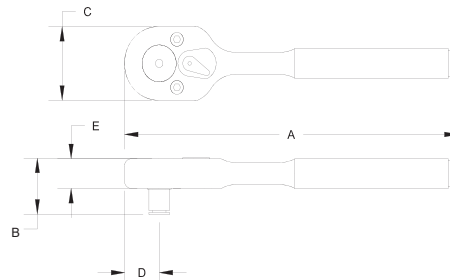

Socket Hex Size	Hex Key Size	Complete Tool Part Number	Ratchet Wrench Part Number	Socket Part Number	Hex Key Part Number						Handle Swing
						A	B	C	D	E	
3/16	1/16"	ZRWA25-18-5	ZATHR250 1/4" SQ Drive	ZRWS25-18	ZRWK-5P	5 11/32"	13/16"	1 1/16"	17/32"	7/16"	4 Degrees
7/32		ZRWA25-22-5		ZRWS25-22							
1/4		ZRWA25-25-5		ZRWS25-25							
9/32		ZRWA25-28-5		ZRWS25-28							
5/16		ZRWA25-31-5		ZRWS25-31							
11/32		ZRWA25-34-5		ZRWS25-34							
7/32	5/64"	ZRWA25-22-6	ZATHR250 1/4" SQ Drive	ZRWS25-22	ZRWK-6P	5 11/32"	13/16"	1 1/16"	17/32"	7/16"	4 Degrees
1/4		ZRWA25-25-6		ZRWS25-25							
9/32		ZRWA25-28-6		ZRWS25-28							
5/16		ZRWA25-31-6		ZRWS25-31							
11/32		ZRWA25-34-6		ZRWS25-34							
3/8		ZRWA25-37-6		ZRWS25-37							
3/8	ZRWA37-37-6	ZATHR375	ZRWS37-37			7 27/32"	1 1/8"	1 13/32"	23/32"	1/2"	5 Degrees
5/16	3/32"	ZRWA25-31-8	ZATHR250 1/4" SQ Drive	ZRWS25-31	ZRWK-8P	5 11/32"	13/16"	1 1/16"	17/32"	7/16"	4 Degrees
11/32		ZRWA25-34-8		ZRWS25-34							
3/8		ZRWA25-37-8		ZRWS25-37							
3/8	3/32"	ZRWA37-37-8	ZATHR375 3/8" SQ Drive	ZRWS37-37	ZRWK-8T	7 27/32"	1 1/8"	1 13/32"	23/32"	1/2"	5 Degrees
7/16		ZRWA37-43-8		ZRWS37-43							
1/2		ZRWA37-50-8		ZRWS37-50							
3/8	1/8"	ZRWA37-37-10	ZATHR375 3/8" SQ Drive	ZRWS37-37	ZRWK-10T	7 27/32"	1 1/8"	1 13/32"	23/32"	1/2"	5 Degrees
7/16		ZRWA37-43-10		ZRWS37-43							
1/2		ZRWA37-50-10		ZRWS37-50							
7/16	5/32"	ZRWA37-43-12	ZATHR375 3/8" SQ Drive	ZRWS37-43	ZRWK-12T	7 27/32"	1 1/8"	1 13/32"	23/32"	1/2"	5 Degrees
1/2		ZRWA37-50-12		ZRWS37-50							

ZATHR250 maximum torque rating is 500 in lbs.



LOK-FAST

Glossary for Quick Change System™

QCA: (Quick Change Installation Assembly) This assembly includes the basic items needed to use the quick change system for Hi-Lok® fastener installation with existing Hi-Lok hand and pneumatic tools.

QCRA: (Quick Change Removal Assembly) This assembly includes the basic items needed to use the quick change system for Hi-Lok® fastener removal with existing Hi-Lok hand and pneumatic tools.

QCR: (Quick Change Receptacle) The receptacle is used to adapt the quick change system to your tooling. All sizes of removal and installation sockets will work with one receptacle. QCR-281 has a standard male hex size of 0.281 (9/32") to adapt to a 9/32 through hex gear on a pneumatic tool or a hand tool.

QCHRS: (Quick Change Removal Socket) The QCHRS is designed to remove Hi-Lok® Fasteners after the hex has been broken off. The QCHRS has a roller pin system that located on the shoulder of the installed fastener. Each socket has a grip range of 0.02" and is offered in 11 sizes to remove fasteners with shoulder sizes from 0.235" - 0.455".

QCRSS: (Quick Change Removal Socket Set) QCRSS is a set of all 11 quick change removal sockets and includes 4 QCK hex tips.

QCHS: (Quick Change Installation Socket) QCHS is designed to be interchangeable with the QCRS and used with the same receptacle for installing Hi-Lok® fasteners. The QCHS comes in 7 standard sizes from QCHS22 (7/32") to QCHS43 (7/16).

QCSS: (Quick Change Installation Socket Set) QCSS is a set of all 7 installation sockets, including 4 QRK hex tips.

QCHA: (Quick Change Hand Installation Assembly)

QCHRA: (Quick Change Hand Removal Assembly)

QCK-4000: Pneumatic tool with complete removal and installation socket sets, including the hand installation and removal assembly.

QCK-4010: Pneumatic tool with installation and removal socket sets.

QCK-4020: Pneumatic tool with installation socket set.

QCK-4030: Pneumatic tool with removal socket set.

QCK-4040: Hand tool with installation and removal socket sets.

QCK-4050: Hand tool with installation socket set.

QCK-4060: Hand tool with removal socket set.

QCK-4070: Pneumatic tool with complete removal and installation socket sets, including the hand installation, removal assembly and additional 4 gear "L" head assembly.

