

The image displays two pieces of industrial tooling against a dark blue background. The upper tool is a long, cylindrical assembly with a complex, multi-faceted metal head. The lower tool is a similar but longer assembly with a hexagonal section near the tip. Both tools are made of polished metal and show signs of use.

ZEPHYR[®]
TOOL
GROUP
LOK-FAST

Blind Fastener Tooling



LOK-FAST

Visu-Lok® Tooling	
Pneumatic Pistol, Master Torque Driver	4
Pneumatic Pistol, Drill-Out Assembly	5
Pneumatic, Right Angle Torque Responsive Assembly	6
Pneumatic, Right Angle Standard Assembly	7
Pneumatic, Right Angle Close Quarter Assembly	8
Hand Tool, Ratchet Assembly	9
Hand Tool, Close Quarter Assembly	10
Hand Tool, Torque Adapters	11
Hand Tool, Drill-Out Assembly	11
Break-Off Gauges	12
Grip Scales	13
Composi-Lok® Tooling	
Pneumatic, Pistol Master Torque Driver Assembly	16
Pneumatic, Right Angle Master Torque Driver Assembly	17
Pneumatic, Right Angle Close Quarter Assembly	18
Hand Tool, Ratchet Assembly	19
Hand Tool, Close Quarter Assembly	20
Hand Torque Adpaters	21
Hand Drill out Assembly	21
Break-Off Gauges	22
Grip Scales	23
Visu-Lok II® Tooling	
Introduction.....	26
Drivenut Interchangeability	27
Pneumatic Pistol Driver Assembly.....	28
Pneumatic, Right Angle Standard Assembly.....	29
Pneumatic, Right Angle Torque Responsive Assembly.....	30
Pneumatic, Right Angle Torque Responsive Integrated	31
Pneumatic, Right Angle Close Quarter Assembly.....	32
Hand Tool, Standard Ratchet Assembly.....	33
Hand Tool, Close Quarter Ratchet Assembly.....	34
Grip Scales	35



LOK-FAST

Composi-Lok II® Tools

Introduction	38-39
Pneumatic Pistol Driver Assembly	40
Pneumatic, Right Angle Standard Assembly	41
Pneumatic, Right Angle Torque Responsive Assembly	42
Pneumatic, Right Angle Torque Responsive w/ Integrated Torque Driver	43
Pneumatic, Right Angle Close Quarter Driver Assembly	44
Hand Tool, Standard Ratchet Assembly	45
Hand Tool, Close Quarter Ratchet Assembly	46
Grip Scales	47

Composi-Lok III® Tools

Pneumatic Pistol Driver Assembly	50
Pneumatic, Right Angle Standard Assembly	51
Hand Tool, Standard Ratchet Assembly	52

Jo-Bolt Kits

4000Kit (Visu-Lok Ratchet Hand Tool)	54
4060Kit (Composi-Lok Right Angle MTDA)	55
4070Kit (Visu-Lok Right Angle MTDA)	56
4080Kit (Composi-Lok Pistol MTDA)	57
4090Kit (Visu-Lok Pistol MTDA)	58
CLHK-101 (Composi-Lok Hand Tool Kit)	59
CLIIHK-101 (Composi-Lok Hand Tool Kit)	59
VLHK-101 (Visu-Lok Hand Tool Kit)	60
VLHK-102 (Visu-Lok Hand Tool Kit)	61
3060KIT (Visu-Lok Hand Tool Kit)	62
HDO-KIT9 (Visu-Lok Removal Hand Tool Kit)	63

Copyright c 1989, 1990, 1992, 1995, 1996, 1998, 1999

All Rights Reserved

Hi-lok®

Hi-Lite®

Hi-Tigue® are all registered Trademarks of Hi-Shear Corporation

Verilite® is a Trademark of Voi-Shan Corporation

C-Lok™ is a Trademark of Cherry Fasteners

QRS® Quick Release Key System is a Registered Trademark of ZEPHYR MANUFACTURING CO., INC./LOK-FAST

U.S. Patent Number 5,305,666

QRK()™ Quick Release Key System is a Trademark of ZEPHYR MANUFACTURING CO., INC./LOK-FAST

Jo-Bolt® Visu-Lok®, Visu-Lok®, Composi-Lok® and Composi-Lok®, are Registered Trademarks of Monogram Aerospace Fasteners

K-Fast® is a Trademark of Kaynar, A fairchild Fastener Company

B-Prime® is a Trademark of Bristol Industries

ZEPHYR TOOL GROUP

201 Hindry Avenue

Inglewood, CA 90301

Tel. 310-410-4907 ▪ Email: sales@zephyrtoolgroup.com ▪ zephyrtoolgroup.com

ZEPHYR[®]
T O O L
G R O U P



TOOLS ENGINEERED TO PERFORM



LOK-FAST

Visu-Lok

Blind Fastener Tools

ZEPHYR TOOL GROUP

201 Hindry Avenue
Inglewood, CA 90301

Tel. 310-410-4907 ▪ Email: sales@zephyrtoolgroup.com ▪ zephyrtoolgroup.com



Master Torque Driver

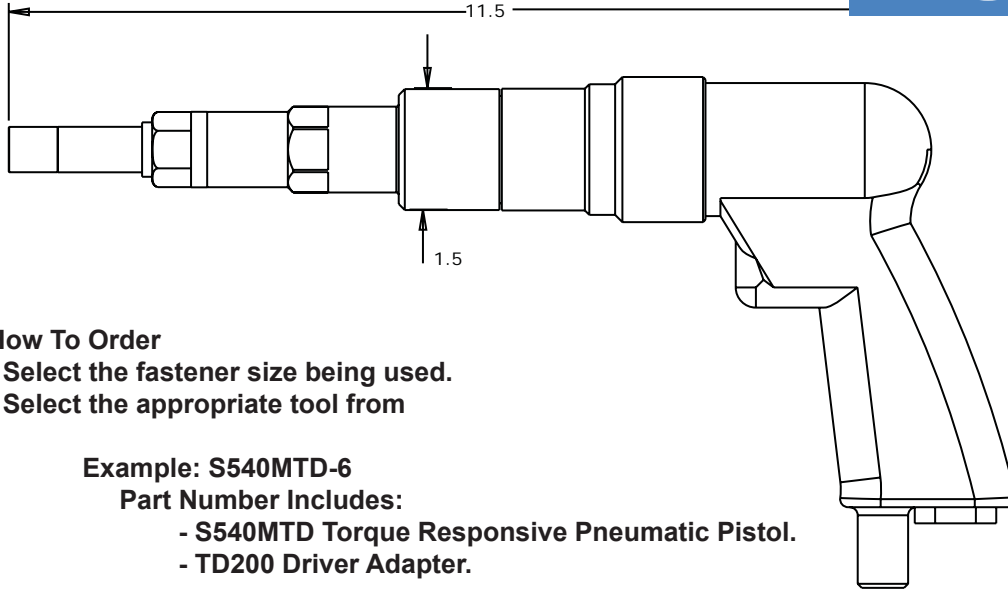

How To Order

- Select the fastener size being used.
- Select the appropriate tool from

Example: S540MTD-6

Part Number Includes:

- S540MTD Torque Responsive Pneumatic Pistol.
- TD200 Driver Adapter.

Pin Dia	Visu-Lok Series	Pneumatic Pistol	Driver Adapter	Nose	Driver
5/32"	flush - 5	S540MTD-5	TD165	PW3652	TD1651
3/16"	flush - 6	S540MTD-6	TD200	PW3002	TD2001
1/4"	flush - 8	S540MTD-8	TD260	PW3602	TD2601
5/16"	flush - 10	S540MTD-10	TD312	PW3122	TD3121
3/8"	flush - 12	S540MTD-12	PT375	PT3752	PT3751
5/32"	protruding - 5	S540MTD-5P	TD165P	PW3652P	TD1651
3/16"	protruding - 6	S540MTD-6P	TD200P	PW3002P	TD2001
1/4"	protruding - 8	S540MTD-8P	TD260P	PW3602P	TD2601
5/16"	protruding - 10	S540MTD-10P	TD312P	PW3122P	TD3121
3/8"	protruding - 12	S540MTD-12P	PT375P	PW3752P	PT3751
5/32"	millable - 5	S540MTD-5A	TD165A	PW3652A	TD1651
3/16"	millable - 6	S540MTD-6A	TD200A	PW3002A	TD2001
1/4"	millable - 8	S540MTD-8A	TD260A	PW3602A	TD2601
5/32"	reduced flush - 5	S540MTD-5T	TD165T	PW3652T	TD1651
3/16"	reduced flush - 6	S540MTD-6T	TD200T	PW3002T	TD2001
1/4"	reduced flush - 8	S540MTD-8T	TD260T	PW3602T	TD2601
5/16"	reduced flush - 10	S540MTD-10T	TD312T	PW3122T	TD3121
3/8"	reduced flush - 12	S540MTD-12T	PT375T	PT3752T	PT3751

* Driver Adapter contains both the Nose and Driver

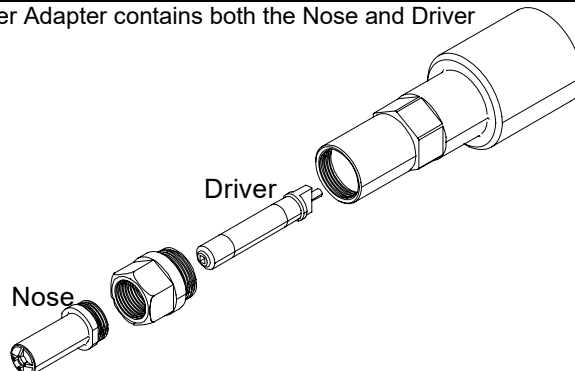

Technical Data

Operating Pressure	90 PSI
Torque Output	220 in-lbs
Motor Speed	540 rpm
Air Consumption (at free speed)	30 cfm
Horse Power Rating	0.5
Weight	3.5lb



Pneumatic Drill-Out

LOK-FAST

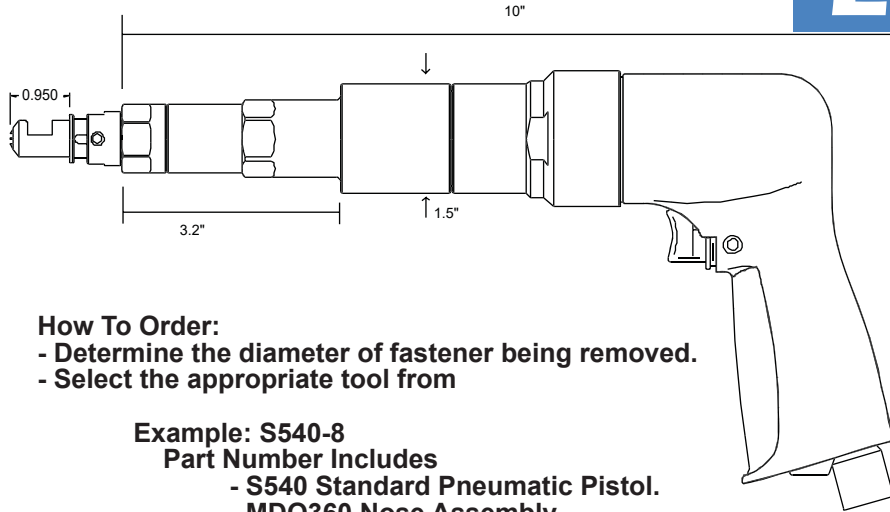

How To Order:

- Determine the diameter of fastener being removed.
- Select the appropriate tool from

Example: S540-8

Part Number Includes

- S540 Standard Pneumatic Pistol.
- MDO360 Nose Assembly.

Dia	Visu-Lok Series	Complete Assy	Drill-Out Assy	Nose	Drill
5/32"	flush - 5	S540-5	MDO365	DO1652	DO1655-5
3/16"	flush - 6	S540-6	MDO300	DO2002	DO1655-6
1/4"	flush - 8	S540-8	MDO360	DO2602	DO1655-8
5/16"	flush - 10	S540-10	MDO312	DO3122	DO1655-10
3/8"	flush - 12	S540-12	MDO375	DO3752	DO1655-12
5/32"	protruding - 5	S540-5P	MDO365P	DO1652P	DO1655-5
3/16"	protruding - 6	S540-6P	MDO300P	DO2002P	DO1655-6
1/4"	protruding - 8	S540-8P	MDO360P	DO2602P	DO1655-8
5/16"	protruding - 10	S540-10P	MDO312P	DO3122P	DO1655-10
3/8"	protruding - 12	S540-12P	MDO375P	DO3752P	DO1655-12
5/32"	millable - 5	S540-5A	MDO365A	DO1652A	DO1655-5
3/16"	millable - 6	S540-6A	MDO300A	DO2002A	DO1655-6
1/4"	millable - 8	S540-8A	MDO360A	DO2602A	DO1655-8
5/32"	reduced flush - 5	S540-5T	MDO365T	DO1652T	DO1655-5
3/16"	reduced flush - 6	S540-6T	MDO300T	DO2002T	DO1655-6
1/4"	reduced flush - 8	S540-8T	MDO360T	DO2602T	DO1655-8
5/16"	reduced flush - 10	S540-10T	MDO312T	DO3122T	DO1655-10
3/8"	reduced flush - 12	S540-12T	MDO375T	DO3752T	DO1655-12

*Drill out Assembly contains both the Nose and Driver

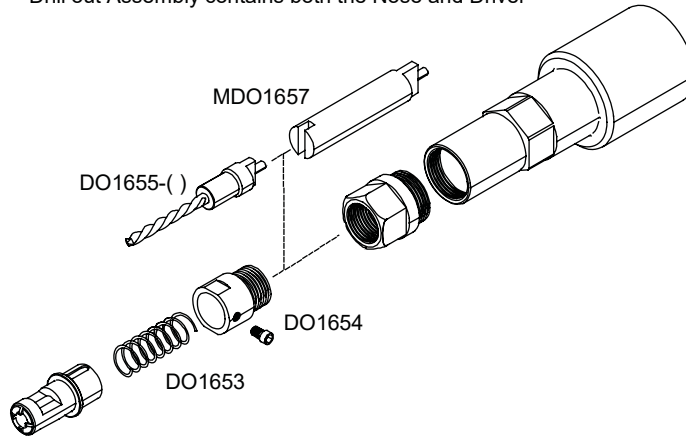

Technical Data	
Operating Pressure	90 PSI
Torque Output	220 in-lbs
Motor Speed	540 rpm
Air Consumption	30 cfm
(at free speed)	
Horse Power Rating	0.5
Weight	3.5lb



Torque Responsive Adapter



How To Order

- Select the fastener size being used.
- Select the appropriate tool from Table below

Example: 7440M-6

Part Number Includes

- 7440M Pneumatic Right Angle Motor.
- PT400 Driver Assembly.

Dia.	Visu-Lok Series	Pneumatic Assembly	Driver Assy	Nose	Driver
5/32"	flush - 5	7440M-5	PT465	PT4652	PT4651
3/16"	flush - 6	7440M-6	PT400	PT4002	PT4001
1/4"	flush - 8	7440M-8	PT460	PT4602	PT4601
5/32"	protruding - 5	7440M-5P	PT465P	PT4652P	PT4651
3/16"	protruding - 6	7440M-6P	PT400P	PT4002P	PT4001
1/4"	protruding - 8	7440M-8P	PT460P	PT4602P	PT4601
5/32"	millable - 5	7440M-5A	PT465A	PT4652A	PT4651
3/16"	millable - 6	7440M-6A	PT400A	PT4002A	PT4001
1/4"	millable - 8	7440M-8A	PT460A	PT4602A	PT4601
5/32"	reduced flush - 5	7440M-5T	PT465T	PT4652T	PT4651
3/16"	reduced flush - 6	7440M-6T	PT400T	PT4002T	PT4001
1/4"	reduced flush - 8	7440M-8T	PT460T	PT4602T	PT4601

*Driver Assembly contains both the Nose and Driver

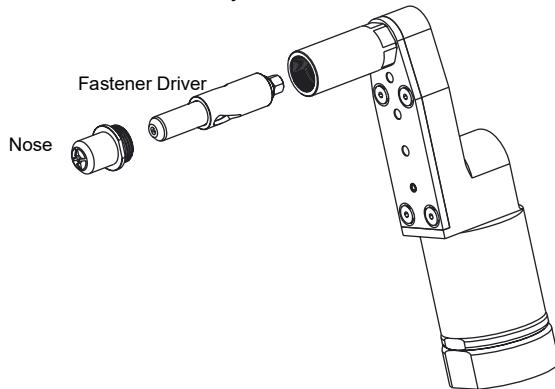

Technical Data	
Operating Pressure	90 PSI
Torque Output	220 in-lbs
Motor Speed	500 rpm
Air Consumption (at free speed)	30 cfm
Horse Power Rating	0.5
Weight	3.5lb



Standard Assembly

LOK-FAST

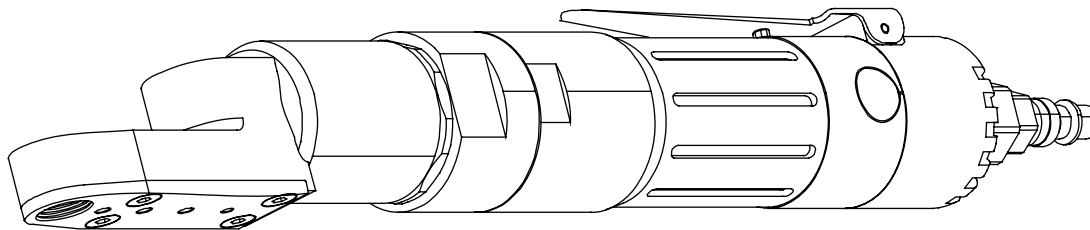

How To Order

- Select the fastener size being used.
- Select the appropriate tool from Table below

Example: 7440-5

Part Number Includes

- 7440 Pneumatic Right Angle Motor.
- PW465 Driver Assembly.

Dia.	Visu-Lok Series	Pneumatic Driver	Driver Assy	Nose	Driver
5/32"	flush - 5	7440-5	PW465	PW3652	PW4651
3/16"	flush - 6	7440-6	PW400	PW3002	PW4001
1/4"	flush - 8	7440-8	PW460	PW3602	PW4601
5/32"	protruding - 5	7440-5P	PW465P	PW3652P	PW4651
3/16"	protruding - 6	7440-6P	PW400P	PW3002P	PW4001
1/4"	protruding - 8	7440-8P	PW460P	PW3602P	PW4601
5/32"	millable - 5	7440-5A	PW465A	PW3652A	PW4651
3/16"	millable - 6	7440-6A	PW400A	PW3002A	PW4001
1/4"	millable - 8	7440-8A	PW460A	PW3602A	PW4601
5/32"	reduced flush - 5	7440-5T	PW465T	PW3652T	PW4651
3/16"	reduced flush - 6	7440-6T	PW400T	PW3002T	PW4001
1/4"	reduced flush - 8	7440-8T	PW460T	PW3602T	PW4601

*Driver Assembly contains both the Nose and Driver

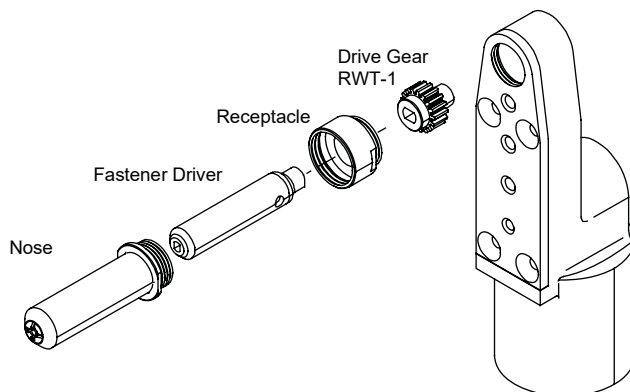

Technical Data	
Operating Pressure	90 PSI
Torque Output	220 in-lbs
Motor Speed	500 rpm
Air Consumption (at free speed)	30 cfm
Horse Power Rating	0.5
Weight	3.5lb



Pneumatic Close Quarter

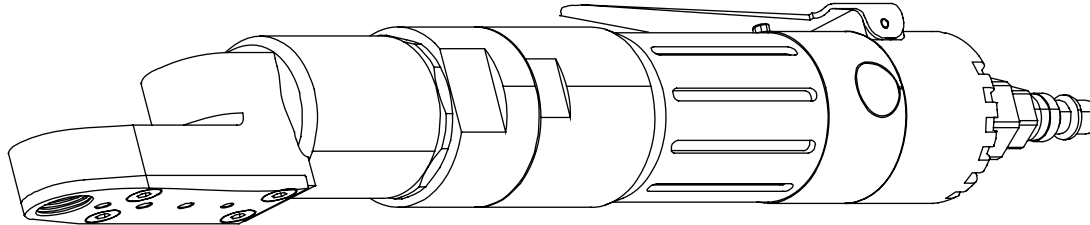

How To Order

- Select the fastener size being used.
- Select the appropriate tool from Table below

Example: 7440C-5

Part Number Includes

- 7440C Pneumatic Right Angle Close Quarter Motor.
- 41165 Nose Tip
- RW5-1 Driver Gear

Dia.	Visu-Lok Series	Pneumatic Driver	Drive Gear	Nose Tip
5/32"	flush - 5	7440C-5	RW5-1	41165
3/16"	flush - 6	7440C-6	RW6-1	41200
1/4"	flush - 8	7440C-8	RW8-1	41260
5/32"	protruding - 5	7440C-5P	RW5-1	41165P
3/16"	protruding - 6	7440C-6P	RW6-1	41200P
1/4"	protruding - 8	7440C-8P	RW8-1	41260P
5/32"	millable - 5	7440C-5A	RW5-1	41165A
3/16"	millable - 6	7440C-6A	RW6-1	41200A
1/4"	millable - 8	7440C-8A	RW8-1	41260A
5/32"	reduced flush - 5	7440C-5T	RW5-1	41165T
3/16"	reduced flush - 6	7440C-6T	RW6-1	41200T
1/4"	reduced flush - 8	7440C-8T	RW8-1	41260T

Technical Data	
Operating Pressure	90 PSI
Torque Output	220 in-lbs
Motor Speed	500 rpm
Air Consumption (at free speed)	30 cfm
Horse Power Rating	0.5
Weight	3.5lb

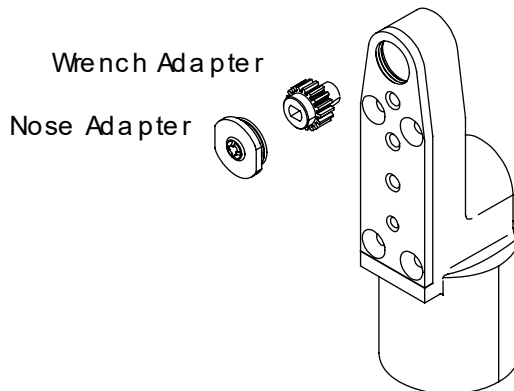



Ratchet Hand Tool

LOK-FAST



How To Order

- Determine the type (flush, protruding, etc) and size of the fastener.
- Refer to the table to select the correct part number for the required tool.

Example: HWF165

Part Number Includes

- HW300 Ratchet Wrench
- HW1650 Adapter Assembly
(HW1652, HW1651)

Dia.	Visu-Lok Series	Complete Assembly	Driver Assembly	Nose	Wrench Driver
5/32"	flush - 5	HWF165	HW1650	HW1652	HW1651
3/16"	flush - 6	HWF200	HW2000	HW2002	HW2001
1/4"	flush - 8	HWF260	HW2600	HW2602	HW2601
5/16"	flush - 10	HWF312	HW3120	HW3122	HW3121
3/8"	flush - 12	HWF375	HW3750	HW3752	HW3751
5/32"	protruding - 5	HWP165	HW1650P	HW1652P	HW1651
3/16"	protruding - 6	HWP200	HW2000P	HW2002P	HW2001
1/4"	protruding - 8	HWP260	HW2600P	HW2602P	HW2601
5/16"	protruding - 10	HWP312	HW3120P	HW3122P	HW3121
3/8"	protruding - 12	HWP375	HW3750P	HW3752P	HW3751
5/32"	millable - 5	HWA165	HW1650A	HW1652A	HW1651
3/16"	millable - 6	HWA200	HW2000A	HW2002A	HW2001
1/4"	millable - 8	HWA260	HW2600A	HW2602A	HW2601
5/32"	reduced flush - 5	HWT165	HW1650T	HW1652T	HW1651
3/16"	reduced flush - 6	HWT200	HW2000T	HW2002T	HW2001
1/4"	reduced flush - 8	HWT260	HW2600T	HW2602T	HW2601
5/16"	reduced flush - 10	HWT312	HW3120T	HW3122T	HW3121
3/8"	reduced flush - 12	HWT375	HW3750T	HW3752T	HW3751

*Driver Assembly contains both the Nose and Driver



Close Quarter Hand Tool

LOK-FAST

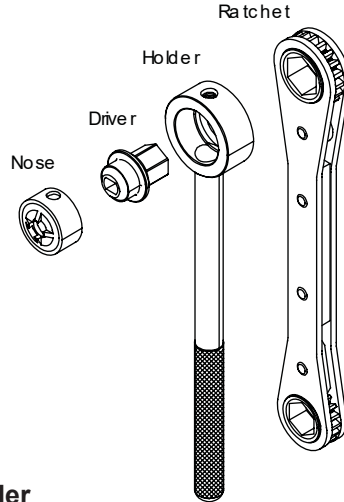

How To Order

- Select the fastener size.
- Refer to the table to select the correct part number for the tool.

Example: HWF5

Part Number Includes

- HW101 Ratchet Wrench
- HW102 Adapter Assembly
- HN5 Nose
- HW5 Drive

Dia.	Visu-Lok Series	Complete Assembly	Drive	Nose	Ratchet	Holder
5/32"	flush - 5	HWF5	HW5	HN5	HW101	HW102
3/16"	flush - 6	HWF6	HW6	HN6		
1/4"	flush - 8	HWF8	HW8	HN8	HW401	HW402
5/16"	flush - 10	HWF10	HW10	HN10		
3/8"	flush - 12	HWF12	HW12	HN12		
5/32"	protruding - 5	HWP5	HW5	HN5P	HW101	HW102
3/16"	protruding - 6	HWP6	HW6	HN6P		
1/4"	protruding - 8	HWP8	HW8	HN8P	HW401	HW402
5/16"	protruding - 10	HWP10	HW10	HN10P		
3/8"	protruding - 12	HWP12	HW12	HN12P		
5/32"	millable - 5	HWA5	HW5	HN5A	HW101	HW102
3/16"	millable - 6	HWA6	HW6	HN6A		
1/4"	millable - 8	HWA8	HW8	HN8A	HW401	HW402
5/32"	reduced flush - 5	HWT5	HW5	HN5T		
3/16"	reduced flush - 6	HWT6	HW6	HN6T		
1/4"	reduced flush - 8	HWT8	HW8	HN8T	HW401	HW402
5/16"	reduced flush - 10	HWT10	HW10	HN10T		
3/8"	reduced flush - 12	HWT12	HW12	HN12T		



Torque Adapter



How To Order:

- Select the fastener size being used.
- Select the appropriate tool part number from the table

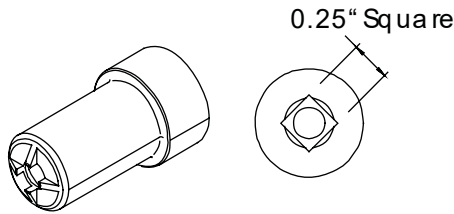

Dia.	Visu-Lok Series	Toque Adapter	Torque (in. lbs.)
5/32"	flush - 5	TOR1652	4.00
3/16"	flush - 6	TOR2002	6.00
1/4"	flush - 8	TOR2602	10.00
5/16"	flush - 10	TOR3122	20.00
3/8"	flush - 12	TOR3752	30.00
5/32"	protruding - 5	TOR1652P	4.00
3/16"	protruding - 6	TOR2002P	6.00
1/4"	protruding - 8	TOR2602P	10.00
5/16"	protruding - 10	TOR3122P	20.00
3/8"	protruding - 12	TOR3752P	30.00
5/32"	millable - 5	TOR1652A	4.00
3/16"	millable - 6	TOR2002A	6.00
1/4"	millable - 8	TOR2602A	10.00
5/32"	reduced flush - 5	TOR1652T	4.00
3/16"	reduced flush - 6	TOR2002T	6.00
1/4"	reduced flush - 8	TOR2602T	10.00
5/16"	reduced flush - 10	TOR3122T	20.00
3/8"	reduced flush - 12	TOR3752T	30.00

Hand Drill-Out

How To Order:

- Select the fastener size being used.
- Select the appropriate tool part number from the table



Dia.	Visu-Lok Series	Hand Drill Out	Drill Size
5/32"	flush - 5	HDO1652	9/64"
3/16"	flush - 6	HDO2002	5/32"
1/4"	flush - 8	HDO2602	13/64"
5/16"	flush - 10	HDO3122	1/4"
3/8"	flush - 12	HDO3752	9/32"
5/32"	protruding - 5	HDO1652P	9/64"
3/16"	protruding - 6	HDO2002P	5/32"
1/4"	protruding - 8	HDO2602P	13/64"
5/16"	protruding - 10	HDO3122P	1/4"
3/8"	protruding - 12	HDO3752P	9/32"
5/32"	millable - 5	HDO1652A	9/64"
3/16"	millable - 6	HDO2002A	5/32"
1/4"	millable - 8	HDO2602A	13/64"
5/32"	reduced flush - 5	HDO1652T	9/64"
3/16"	reduced flush - 6	HDO2002T	5/32"
1/4"	reduced flush - 8	HDO2602T	13/64"
5/16"	reduced flush - 10	HDO3122T	1/4"
3/8"	reduced flush - 12	HDO3752T	9/32"



Visu-Lok Break-Off Gauges

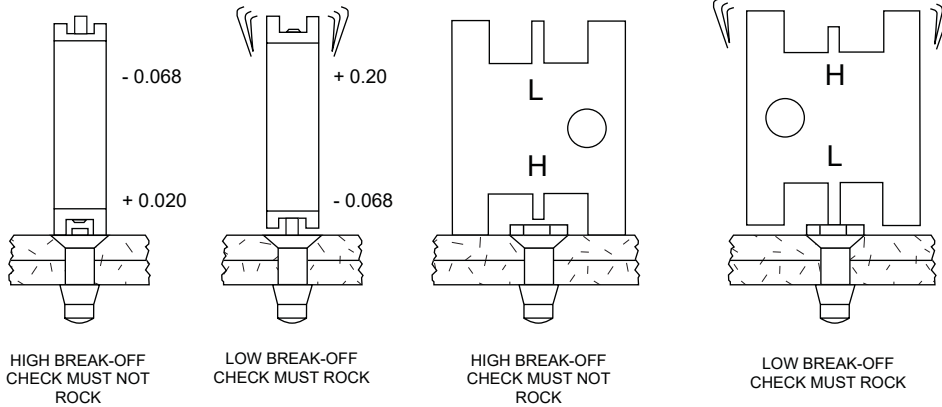

Visu-Lok Series	Leaf Gauges	Break-Off Limits	Round Gauges	Break-Off Limits	Jo-Bolt Series
PLT210-5	3P5	+0.088/+0.000	-	-	-
PLT210-6	3P6	+0.098/+0.010	4P6	-.005/-0.103	P/PO 200
PLT210-8	3P8	+0.135/+0.047	4P8	+0.010/-0.088	P/PO 260
PLT210-10	3P10	+0.146/+0.043	4P10	-.004/-0.117	P/PO 312
PLT210-12	3P12	+0.152/+0.049	4P12	-.028/-0.141	P/PO 375
PLT110-5	3F5	+0.020/-0.068	4F5	+0.020/-0.068	-
PLT110-6	3F6	+0.015/-0.073	4F6	+0.015/-0.073	-
PLT110-8	3F8	+0.010/-0.078	4F8	+0.010/-0.078	-
PLT110-10	3F10	+0.010/-0.083	4F10	+0.010/-0.083	-
PLT110-12	3F12	+0.010/-0.093	4F12	+0.010/-0.093	-
PLT220-5	A3P5	+0.088/+0.000	-	-	-
PLT220-6	A3P6	+0.103/+0.015	-	-	-
PLT220-8	A3P8	+0.130/+0.032	-	-	-
PLT220-10	A3P10	+0.130/+0.027	-	-	-
PLT220-12	A3P12	+0.130/+0.027	-	-	-
PLT120-5	-	-	A4F5-LS	+0.082/-0.006	-
PLT120-6	-	-	A4F6-LS	+0.072/-0.016	-
PLT120-8	-	-	A4F8-LS	+0.072/-0.031	-
PLT120-10	-	-	A4F10-LS	+0.072/-0.031	-
PLT120-12	-	-	A4F12-LS	+0.072/-0.031	-
PLT130-5	3P5	+0.088/+0.000	-	-	-
PLT130-6	3P6	+0.098/+0.010	4FA6	+0.025/-0.069	SHFA/FAO 200
PLT130-8	3P6	+0.098/+0.010	4FA8	+0.026/-0.069	SHFA/FAO 260
PLT230-5	3P5	+0.088/+0.000	-	-	-
PLT230-6	3PA6	+0.103/+0.015	-	-	-
PLT230-8	3P8	+0.135/+0.047	-	-	-
PLT1058-5	-	-	LF5-F5	+0.088/+0.000	-
PLT1058-6	-	-	LF5-F5	+0.088/+0.000	-
PLT1058-8	-	-	LF5-F8	+0.098/+0.000	-
PLT1058-10	-	-	LF5-F10	+0.103/+0.000	-
PLT1058-12	-	-	LF5-F10	+0.103/+0.000	-



Visu-Lok Grip Scales



Grip Scale Part #: LFVLG-1

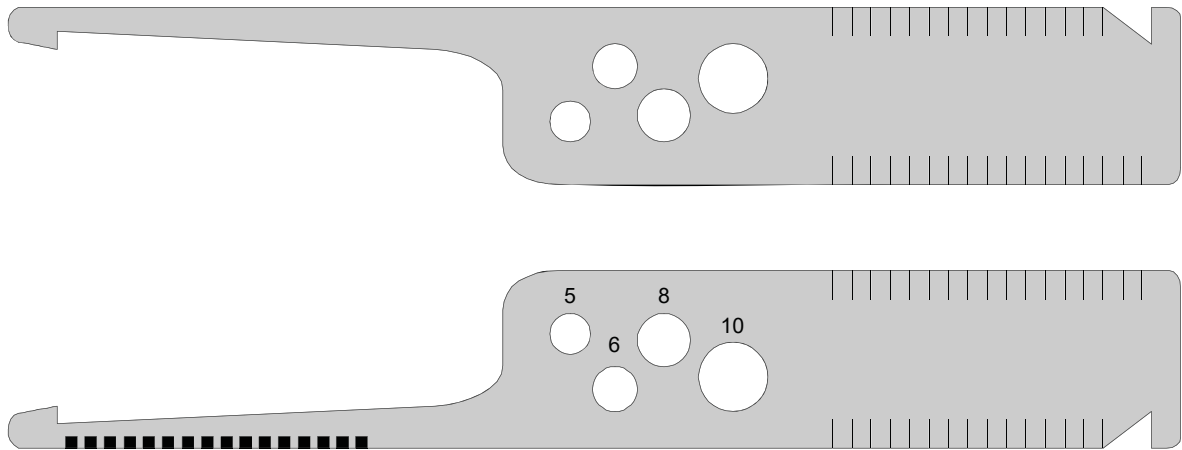

Selection of Grip Length

In measuring hole depth take reading where the skin surface meets the number or line on gauge. If directly on a line use either the indicated grip or the next longer grip.

In cases where there a tapered sheet condition exists, determine grip length at the hole centerline. The taper must not exceed 7° to ensure the proper performance of the fastener.

ZEPHYR[®]
TOOL
GROUP



TOOLS ENGINEERED TO PERFORM



LOK-FAST

ZEPHYR TOOL GROUP

201 Hindry Avenue
Inglewood, CA 90301

Tel. 310-410-4907 ■ Email: sales@zephyrtoolgroup.com ■ zephyrtoolgroup.com

ZEPHYR[®]
T O O L
G R O U P



TOOLS ENGINEERED TO PERFORM



LOK-FAST

Composi-Lok Blind Fastener Tools

ZEPHYR TOOL GROUP

201 Hindry Avenue
Inglewood, CA 90301

Tel. 310-410-4907 ▪ Email: sales@zephyrtoolgroup.com ▪ zephyrtoolgroup.com



Composi-Lok Master Torque Driver

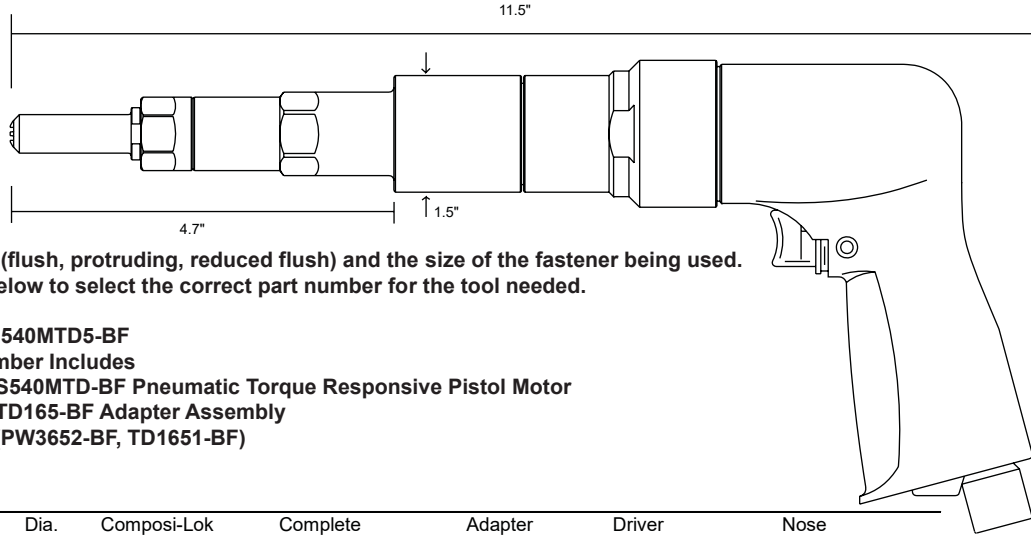

How To Order:

- Determine the type (flush, protruding, reduced flush) and the size of the fastener being used.
- Refer to the table below to select the correct part number for the tool needed.

Example: S540MTD5-BF

Part Number Includes

- S540MTD-BF Pneumatic Torque Responsive Pistol Motor
- TD165-BF Adapter Assembly (PW3652-BF, TD1651-BF)

Dia.	Composi-Lok Series	Complete Assembly	Adapter Assembly	Driver	Nose
5/32"	flush - 5	S540MTD5-BF	TD165-BF	TD1651-BF	PW3652-BF
3/16"	flush - 6	S540MTD6-BF	TD200-BF	TD2001-BF	PW3002-BF
7/32"	flush - 7	S540MTD7-BF	TD220-BF	TD7-BF	PW7F-BF
1/4"	flush - 8	S540MTD8-BF	TD260-BF	TD2601-BF	PW3602-BF
9/32"	flush - 9	S540MTD9-BF	PT280-BF	PT9-BF	PT9F-BF
5/16"	flush - 10	S540MTD10-BF	PT312-BF	PT10-BF	PT10F-BF
11/32"	flush - 11	S540MTD11-BF	PT340-BF	PT11-BF	PT11F-BF
3/8"	flush - 12	S540MTD12-BF	PT375-BF	PT12-BF	PT12F-BF
5/32"	protruding - 5	S540MTD5P - BF	TD165P-BF	TD1651-BF	PW3652P-BF
3/16"	protruding - 6	S540MTD6P - BF	TD200P-BF	TD2001-BF	PW3002P-BF
7/32"	protruding - 7	S540MTD7P - BF	TD220P-BF	TD7-BF	PW7P-BF
1/4"	protruding - 8	S540MTD8P - BF	TD260P-BF	TD2601-BF	PW3602P-BF
9/32"	protruding - 9	S540MTD9P - BF	PT280P-BF	PT9-BF	PT9P-BF
5/16"	protruding - 10	S540MTD10P - BF	PT312P-BF	PT10-BF	PT10P-BF
11/32"	protruding - 11	S540MTD11P - BF	PT340P-BF	PT11-BF	PT11P-BF
3/8"	protruding - 12	S540MTD12P - BF	PT375P-BF	PT12-BF	PT12P-BF
5/32"	reduced flush - 5	S540MTD5T-BF	TD165T-BF	TD1651-BF	PW3652T-BF
3/16"	reduced flush - 6	S540MTD6T-BF	TD200T-BF	TD2001-BF	PW3002T-BF
7/32"	reduced flush - 7	S540MTD7T-BF	TD220T-BF	TD7-BF	PW7FT-BF
1/4"	reduced flush - 8	S540MTD8T-BF	TD260T-BF	TD2601-BF	PW3602T-BF
9/32"	reduced flush - 9	S540MTD9T-BF	PT280T-BF	PT9-BF	PT9FT-BF
5/16"	reduced flush - 10	S540MTD10T-BF	PT312T-BF	PT10-BF	PT10FT-BF
11/32"	reduced flush - 11	S540MTD11T-BF	PT340T-BF	PT11-BF	PT11FT-BF
3/8"	reduced flush - 12	S540MTD12T-BF	PT375T-BF	PT12-BF	PT12FT-BF

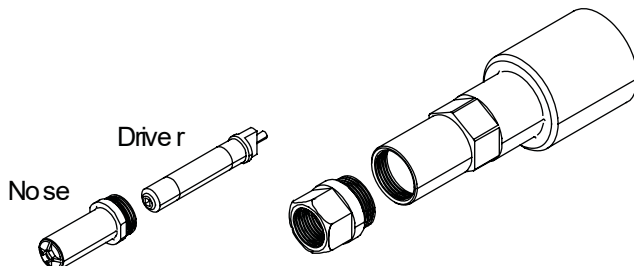

Technical Data

Operating Pressure	90 PSI
Torque Output	220 in-lbs
Motor Speed	540 rpm
Air Consumption (at free speed)	30 cfm
Horse Power Rating	0.5
Weight	3.5lb



Composi-Lok Right Angle Master Torque Driver



How To Order:

- Determine the type (flush, protruding, reduced flush) and the size of the fastener being used.
- Refer to the table below to select the correct part number for the tool needed.

Example: 7440M5-BF

Part Number Includes

- 7440M Torque Responsive Pneumatic Wrench Motor
- TD565-BF Adapter Assembly
(TD5652-BF, TD5651-BF)

Dia.	Composi-Lok Series	Complete Assembly	Adapter Assembly	Wrench Driver	Nose Adapter
5/32"	flush - 5	7440M5-BF	TD565-BF	TD5651-BF	TD5652-BF
3/16"	flush - 6	7440M6-BF	TD500-BF	TD5001-BF	TD5002-BF
7/32"	flush - 7	7440M7-BF	TD520-BF	TD5201-BF	TD5202-BF
1/4"	flush - 8	7440M8-BF	TD560-BF	TD5601-BF	TD5602-BF
5/32"	protruding - 5	7440M5P-BF	TD565P-BF	TD5651-BF	TD5652P-BF
3/16"	protruding - 6	7440M6P-BF	TD500P-BF	TD5001-BF	TD5002P-BF
7/32"	protruding - 7	7440M7P-BF	TD520P-BF	TD5201-BF	TD5202P-BF
1/4"	protruding - 8	7440M8P-BF	TD560P-BF	TD5601-BF	TD5602P-BF
5/32"	reduced flush - 5	7440M5T-BF	TD565T-BF	TD5651-BF	TD5652T-BF
3/16"	reduced flush - 6	7440M6T-BF	TD500T-BF	TD5001-BF	TD5002T-BF
7/32"	reduced flush - 7	7440M7T-BF	TD520T-BF	TD5201-BF	TD5202T-BF
1/4"	reduced flush - 8	7440M8T-BF	TD560T-BF	TD5601-BF	TD5602T-BF

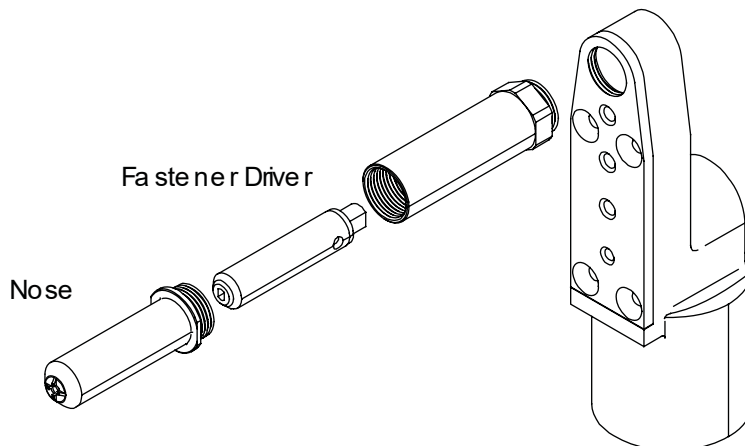

Technical Data

Operating Pressure	90 PSI
Torque Output	220 in-lbs
Motor Speed	500 rpm
Air Consumption (at free speed)	30 cfm
Horse Power Rating	0.5
Weight	3.5lb



Composi-Lok Right Angle Close Quarter

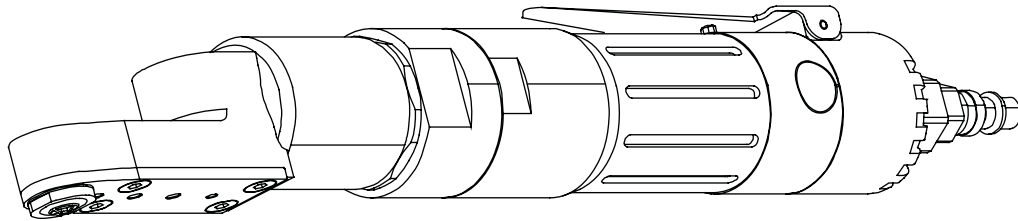

How To Order:

- Determine the type (flush, protruding, reduced flush) and the size of the fastener being used.
- Refer to the table below to select the correct part number for the tool needed.

Example: 7440C5-BF

Part Number Includes

- 7440C Close Quarters Pneumatic Motor
- 41165-BF Nose Adapter
- RW5-1-BF Wrench Adapter

Dia.	Composi-Lok Series	Complete Assembly	Drive Gear	Nose
5/32"	flush - 5	7440C5-BF	RW5-1-BF	41165-BF
3/16"	flush - 6	7440C6-BF	RW6-1-BF	41200-BF
7/32"	flush - 7	7440C7-BF	RW7-1-BF	41220-BF
1/4"	flush - 8	7440C8 - BF	RW8-1-BF	41260-BF
5/32"	protruding - 5	7440C5P-BF	RW5-1-BF	41165P-BF
3/16"	protruding - 6	7440C6P-BF	RW6-1-BF	41200P-BF
7/32"	protruding - 7	7440C7P-BF	RW7-1-BF	41220P-BF
1/4"	protruding - 8	7440C8P-BF	RW8-1-BF	41260P-BF
5/32"	reduced flush - 5	7440C5T-BF	RW5-1-BF	41165T-BF
3/16"	reduced flush - 6	7440C6T-BF	RW6-1-BF	41200T-BF
7/32"	reduced flush - 7	7440C7T-BF	RW7-1-BF	41220T-BF
1/4"	reduced flush - 8	7440C8T-BF	RW8-1-BF	41260T-BF

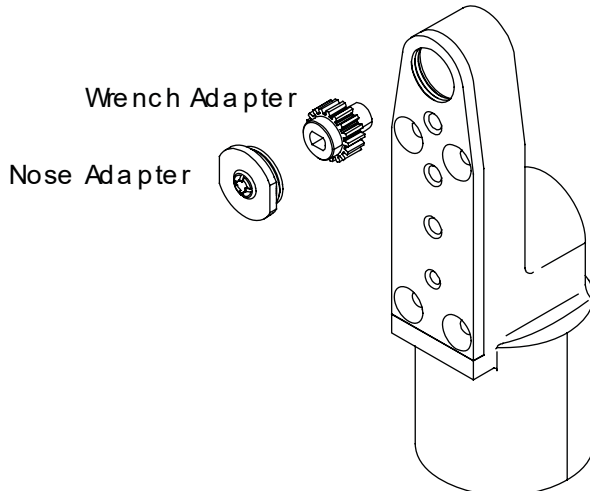

Technical Data

Operating Pressure	90 PSI
Torque Output	220 in-lbs
Motor Speed	500 rpm
Air Consumption (at free speed)	30 cfm
Horse Power Rating	0.5
Weight	3.5lb



Composi-Lok Ratchet Hand Tool



How To Order:

- Determine the type (flush, protruding, reduced flush) and the size of the fastener being used.
- Refer to the table below to select the correct part number for the tool needed.

Example: HW165-BF

Part Number Includes

- HW300 Ratchet Wrench
- HW202 Handle
- HW1650-BF Adapter Assembly
(HW1652-BF, HW1651-BF)

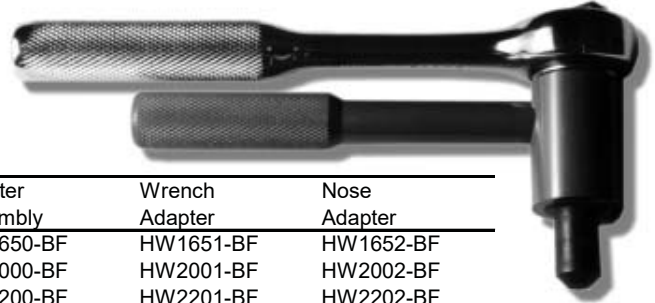

Dia.	Composi-Lok Series	Complete Assembly	Adapter Assembly	Wrench Adapter	Nose Adapter
5/32"	flush - 5	HWF165-BF	HW1650-BF	HW1651-BF	HW1652-BF
3/16"	flush - 6	HWF200-BF	HW2000-BF	HW2001-BF	HW2002-BF
7/32"	flush - 7	HWF220-BF	HW2200-BF	HW2201-BF	HW2202-BF
1/4"	flush - 8	HWF260-BF	HW2600-BF	HW2601-BF	HW2602-BF
9/32"	flush - 9	HWF280-BF	HW2800-BF	HW2801-BF	HW2802-BF
5/16"	flush - 10	HWF312-BF	HW3120-BF	HW3121-BF	HW3122-BF
11/32"	flush - 11	HWF340-BF	HW3400-BF	HW3401-BF	HW3402-BF
3/8"	flush - 12	HWF375-BF	HW3750-BF	HW3751-BF	HW3752-BF
5/32"	protruding - 5	HWP165-BF	HW1650P-BF	HW1651-BF	HW1652P-BF
3/16"	protruding - 6	HWP200-BF	HW2000P-BF	HW2001-BF	HW2002P-BF
7/32"	protruding - 7	HWP220-BF	HW2200P-BF	HW2201-BF	HW2202P-BF
1/4"	protruding - 8	HWP260-BF	HW2600P-BF	HW2601-BF	HW2602P-BF
9/32"	protruding - 9	HWP280-BF	HW2800P-BF	HW2801-BF	HW2802P-BF
5/16"	protruding - 10	HWP312-BF	HW3120P-BF	HW3121-BF	HW3122P-BF
11/32"	protruding - 11	HWP340-BF	HW3400P-BF	HW3401-BF	HW3402P-BF
3/8"	protruding - 12	HWP375-BF	HW3750P-BF	HW3751-BF	HW3752P-BF
5/32"	reduced flush - 5	HWT165-BF	HW1650T-BF	HW1651-BF	HW1652T-BF
3/16"	reduced flush - 6	HWT200-BF	HW2000T-BF	HW2001-BF	HW2002T-BF
7/32"	reduced flush - 7	HWT220-BF	HW2200T-BF	HW2201-BF	HW2202T-BF
1/4"	reduced flush - 8	HWT260-BF	HW2600T-BF	HW2601-BF	HW2602T-BF
9/32"	reduced flush - 9	HWT280-BF	HW2800T-BF	HW2801-BF	HW2802T-BF
5/16"	reduced flush - 10	HWT312-BF	HW3120T-BF	HW3121-BF	HW3122T-BF
11/32"	reduced flush - 11	HWT340-BF	HW3400T-BF	HW3401-BF	HW3402T-BF
3/8"	reduced flush - 12	HWT375-BF	HW3750T-BF	HW3751-BF	HW3752T-BF

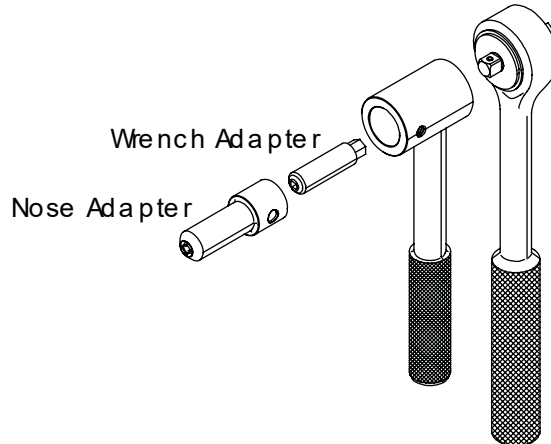



Composi-Lok Close Quarter Hand Tool



How To Order:

- Determine the type (flush, protruding, reduced flush) and the size of the fastener being used.
- Refer to the table below to select the correct part number for the tool needed.

Example: HW5-BF

Part Number Includes

- HW401 Ratchet
- HW402 Holder
- HN5-BF Nose Adapter
- HW5-BF Wrench Adapter

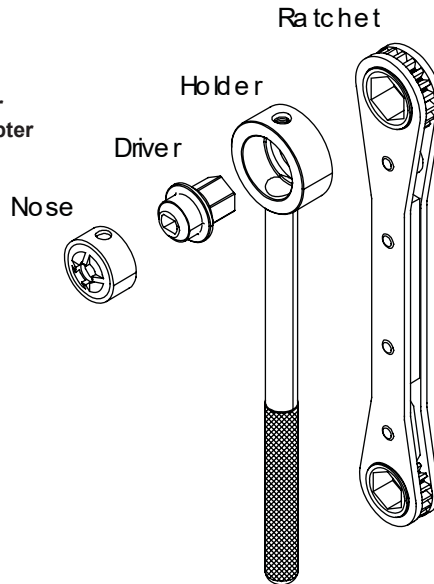

Dia.	Composi-Lok Series	Complete Assembly	Driver	Nose	Ratchet	Holder
5/32"	flush - 5	HWF5-BF	HW5-BF	HN5-BF		
3/16"	flush - 6	HWF6-BF	HW6-BF	HN6-BF	HW101	HW102
7/32"	flush - 7	HWF7-BF	HW7-BF	HN7-BF		
1/4"	flush - 8	HWF8-BF	HW8-BF	HN8-BF		
9/32"	flush - 9	HWF9-BF	HW9-BF	HN9-BF	HW401	HW402
5/16"	flush - 10	HWF10-BF	HW10-BF	HN10-BF		
11/32"	flush - 11	HWF11-BF	HW11-BF	HN11-BF		
3/8"	flush - 12	HWF12-BF	HW12-BF	HN12-BF		
5/32"	protruding - 5	HWP5-BF	HW5-BF	HN5P-BF	HW101	HW102
3/16"	protruding - 6	HWP6-BF	HW6-BF	HN6P-BF		
7/32"	protruding - 7	HWP7-BF	HW7-BF	HN7P-BF		
1/4"	protruding - 8	HWP8-BF	HW8-BF	HN8P-BF		
9/32"	protruding - 9	HWP9-BF	HW9-BF	HN9P-BF	HW401	HW402
5/16"	protruding - 10	HWP10-BF	HW10-BF	HN10P-BF		
11/32"	protruding - 11	HWP11-BF	HW11-BF	HN11P-BF		
3/8"	protruding - 12	HWP12-BF	HW12-BF	HN12P-BF		
5/32"	reduced flush - 5	HWT5-BF	HW5-BF	HN5T-BF	HW101	HW102
3/16"	reduced flush - 6	HWT6-BF	HW6-BF	HN6T-BF		
7/32"	reduced flush - 7	HWT7-BF	HW7-BF	HN7T-BF		
1/4"	reduced flush - 8	HWT8-BF	HW8-BF	HN8T-BF		
9/32"	reduced flush - 9	HWT9-BF	HW9-BF	HN9T-BF	HW401	HW402
5/16"	reduced flush - 10	HWT10-BF	HW10-BF	HN10T-BF		
11/32"	reduced flush - 11	HWT11-BF	HW11-BF	HN11T-BF		
3/8"	reduced flush - 12	HWT12-BF	HW12-BF	HN12T-B		



Composi-Lok Hand Torque Adapter

LOK-FAST

Dia.	Composi-Lok Series	Torque Adapter	Torque (in lbs)
5/32"	flush - 05	TOR1652-BF	4.00
3/16"	flush - 06	TOR2002-BF	6.00
7/32"	flush - 07	TOR2202-BF	Contact Fastener Mfg.
1/4"	flush - 08	TOR2602-BF	10.00
9/32"	flush - 09	TOR2802-BF	Contact Fastener Mfg.
5/16"	flush - 10	TOR3122-BF	20.00
11/32"	flush - 11	TOR3402-BF	Contact Fastener Mfg.
3/8"	flush - 12	TOR3702-BF	30.00
5/32"	protruding - 05	TOR1652P-BF	4.00
3/16"	protruding - 06	TOR2002P-BF	6.00
7/32"	protruding - 07	TOR2202P-BF	Contact Fastener Mfg.
1/4"	protruding - 08	TOR2602P-BF	10.00
9/32"	protruding - 09	TOR2802P-BF	Contact Fastener Mfg.
5/16"	protruding - 10	TOR3122P-BF	20.00
11/32"	protruding - 11	TOR3402P-BF	Contact Fastener Mfg.
3/8"	protruding - 12	TOR3702P-BF	30.00
5/32"	reduced flush - 05	TOR1652T-BF	4.00
3/16"	reduced flush - 06	TOR2002T-BF	6.00
7/32"	reduced flush - 07	TOR2202T-BF	Contact Fastener Mfg.
1/4"	reduced flush - 08	TOR2602T-BF	10.00
9/32"	reduced flush - 09	TOR2802T-BF	Contact Fastener Mfg.
5/16"	reduced flush - 10	TOR3122T-BF	20.00
11/32"	reduced flush - 11	TOR3402T-BF	Contact Fastener Mfg.
3/8"	reduced flush - 12	TOR3702T-BF	30.00

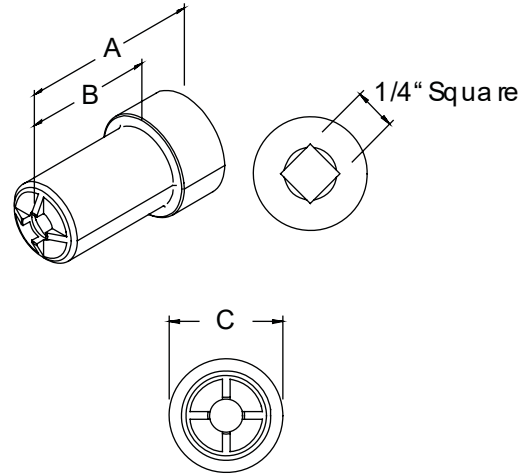

Composi-Lok Hand Drill-Out

How To Order:

- Select the fastener type (flush, protruding, reduced flush) and size being used.
- Select the appropriate tool part number from the table

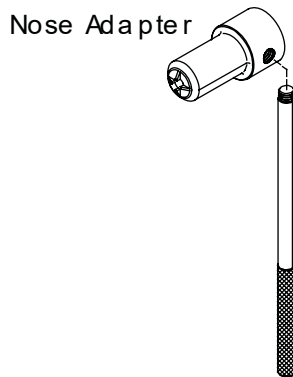

Dia.	Series	Hand Drill Out	Drill Size
5/32"	flush - 5	HDO1652	9/64"
3/16"	flush - 6	HDO2002	5/32"
1/4"	flush - 8	HDO2602	13/64"
5/16"	flush - 10	HDO3122	1/4"
3/8"	flush - 12	HDO3752	9/32"
5/32"	protruding - 5	HDO1652P	9/64"
3/16"	protruding - 6	HDO2002P	5/32"
1/4"	protruding - 8	HDO2602P	13/64"
5/16"	protruding - 10	HDO3122P	1/4"
3/8"	protruding - 12	HDO3752P	9/32"
5/32"	millable - 5	HDO1652A	9/64"
3/16"	millable - 6	HDO2002A	5/32"
1/4"	millable - 8	HDO2602A	13/64"
5/32"	reduced flush - 5	HDO1652T	9/64"
3/16"	reduced flush - 6	HDO2002T	5/32"
1/4"	reduced flush - 8	HDO2602T	13/64"
5/16"	reduced flush - 10	HDO3122T	1/4"
3/8"	reduced flush - 12	HDO3752T	9/32"



Composi-Lok Break-Off Gauges

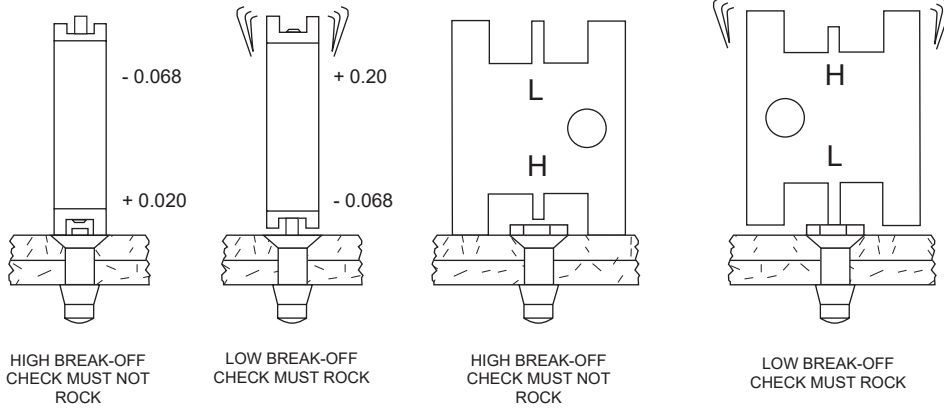

Dia	Composi-Lok Series	Leaf Gauges	Round Gauges	Break-Off Limits
5/32"	MBF2010-05	LFP7-CL	LF8-F5	+ .103/+ .000
5/32"	MBF2011-05	LFP7-CL	LF8-F5	+ .103/+ .000
5/32"	MBF2012-05	LFP7-CL	LF8-F5	+ .103/+ .000
5/32"	MBF2013-05	LFP7-CL	LF8-F5	+ .103/+ .000
3/16"	MBF2010-06	LFP7-CL	LF8-F6	+ .103/+ .000
3/16"	MBF2011-06	LFP7-CL	LF8-F6	+ .103/+ .000
3/16"	MBF2012-06	LFP7-CL	LF8-F6	+ .103/+ .000
3/16"	MBF2013-06	LFP7-CL	LF8-F6	+ .103/+ .000
7/32"	MBF2010-07	LFP7-CL	LF8-F7	+ .103/+ .000
7/32"	MBF2011-07	LFP7-CL	LF8-F7	+ .103/+ .000
7/32"	MBF2012-07	LFP7-CL	LF8-F7	+ .103/+ .000
7/32"	MBF2013-07	LFP7-CL	LF8-F7	+ .103/+ .000
1/4"	MBF2010-08	LFP7-CL	LF8-F8	+ .103/+ .000
1/4"	MBF2011-08	LFP7-CL	LF8-F8	+ .103/+ .000
1/4"	MBF2012-08	LFP7-CL	LF8-F8	+ .103/+ .000
1/4"	MBF2013-08	LFP7-CL	LF8-F8	+ .103/+ .000
9/32"	MBF2010-09	LFP7-CL	LF8-F9	+ .103/+ .000
9/32"	MBF2011-09	LFP7-CL	LF8-F9	+ .103/+ .000
9/32"	MBF2012-09	LFP7-CL	LF8-F9	+ .103/+ .000
9/32"	MBF2013-09	LFP7-CL	LF8-F9	+ .103/+ .000
5/16"	MBF2010-10	LFP7-CL	LF8-F10	+ .103/+ .000
5/16"	MBF2011-10	LFP7-CL	LF8-F10	+ .103/+ .000
5/16"	MBF2012-10	LFP7-CL	LF8-F10	+ .103/+ .000
5/16"	MBF2013-10	LFP7-CL	LF8-F10	+ .103/+ .000
11/32"	MBF2010-11	LFP7-CL	LF8-F11	+ .103/+ .000
11/32"	MBF2011-11	LFP7-CL	LF8-F11	+ .103/+ .000
11/32"	MBF2012-11	LFP7-CL	LF8-F11	+ .103/+ .000
11/32"	MBF2013-11	LFP7-CL	LF8-F11	+ .103/+ .000
3/8"	MBF2010-12	LFP7-CL	LF8-F12	+ .103/+ .000
3/8"	MBF2011-12	LFP7-CL	LF8-F12	+ .103/+ .000
3/8"	MBF2012-12	LFP7-CL	LF8-F12	+ .103/+ .000
3/8"	MBF2013-12	LFP7-CL	LF8-F12	+ .103/+ .000



Composi-Lok Grip Scales



Grip Scale Part #: LFCLG-1 & LFCLG-2

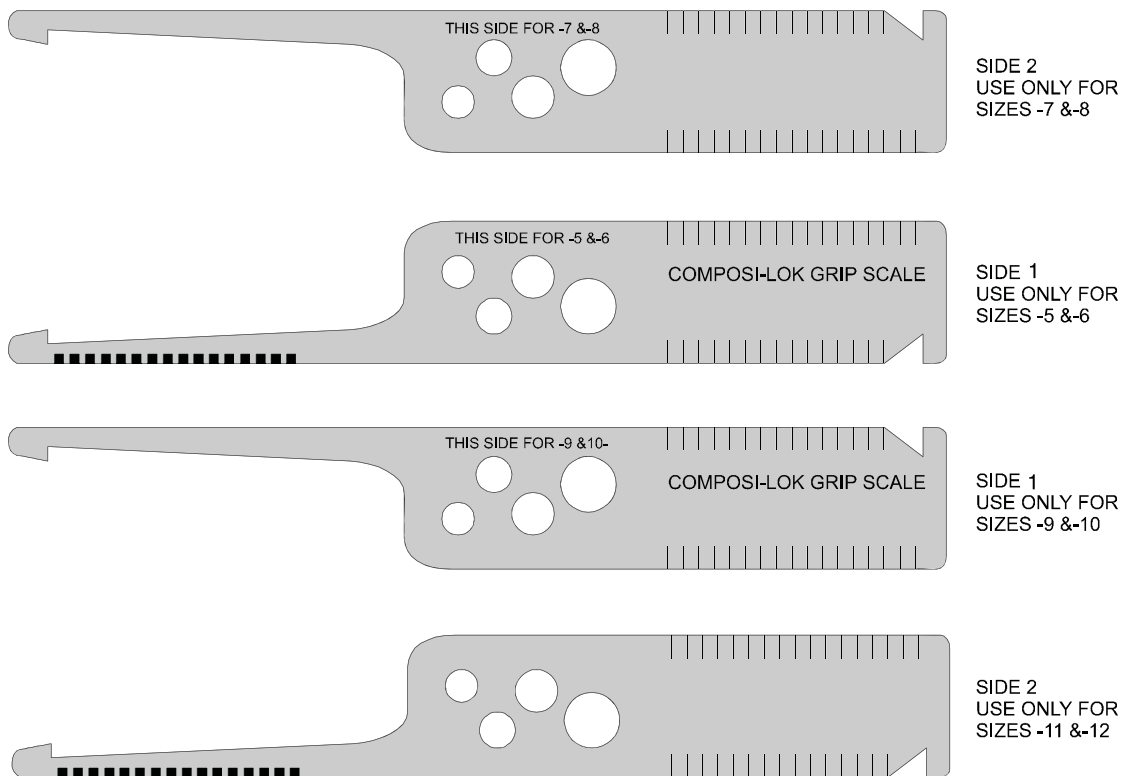

Selection of Grip Length

In measuring hole depth take reading where the skin surface meets the number or line on gauge. If directly on a line use either the indicated grip or the next longer grip.

In cases where there a tapered sheet condition exists, determine grip length at the hole centerline. The taper must not exceed 7° to ensure the proper performance of the fastener.

ZEPHYR[®]
T O O L
G R O U P



TOOLS ENGINEERED TO PERFORM

ZEPHYR[®]
SCREWDRIVING TOOLS

KWIK-LOK[™]
TEMPORARY FASTENERS

ZEPHYR[®]
AEROSPACE HAND & PNEUMATIC TOOLS

LOK-FAST[™]
AEROSPACE FASTENER TOOLS

Martin[™]
AIRCRAFT TOOL

LOK-FAST

ZEPHYR TOOL GROUP

201 Hindry Avenue
Inglewood, CA 90301

Tel. 310-410-4907 ■ Email: sales@zephyrtoolgroup.com ■ zephyrtoolgroup.com

ZEPHYR[®]
T O O L
G R O U P



TOOLS ENGINEERED TO PERFORM



LOK-FAST

Visu-Lok II

Blind Fastener Tools

ZEPHYR TOOL GROUP

201 Hindry Avenue
Inglewood, CA 90301

Tel. 310-410-4907 ■ Email: sales@zephyrtoolgroup.com ■ zephyrtoolgroup.com



Universal Nose Tip™ System for Installing Drive-Nut Type Fasteners



Driver Model #	Universal Nose Tip	Nose Tip Connector	Wrench Adapter	Torque Driver
S540MTD / S540MTD-BF Pneumatic Pistol				
7440 - 90° Right Angle Driver				
7440M / 7440M-BF 90° Pneumatic Torque Responsive				
7440M / 7440M-BF Integrated Wrench / Torque Driver				
7440C Close Quarter 90° Right Angle				
HW200 / HW300 Standard Ratchet Hand Tool				
HW100 / HW400 Close Quarter Ratchet Hand Tool				

Universal Interchangeable Nose Tips

Installation tools have been simplified in the "DRIVE NUT" fastener system in both Visu-Lok II® and Composi-Lok II®

LOK-FAST has further simplified the tooling with UNIVERSAL NOSE TIP™. Now, for a given size range any nose tip may be interchangeable with any driver.

An installation tool consists of a driver and an adapter assembly. The adapter assembly is comprised of a nose adapter to engage the corebolt through rotation to clamp-up and break-off. In most cases, for a given driver, the LOK-FAST UNIVERSAL NOSE TIP™ SYSTEM uses only three complete nose adapters for all the fastener head styles, and for the complete range of sizes from 5/32" to 3/8".

Two Part Nose Adapter

The nose adapter is now a two piece design consisting of the Universal Nose Tip™ and the Nose Tip Connector™. The nose tip engages the fastener drivenut, and the nose tip is threaded onto the connector to form a complete installation tool. The two piece design allows interchanging of the nose tips among all driver configurations and further allows interchangeability between Visu-Lok II® and Composi-Lok II® installation tools. The nose tip may be removed with a standard allen wrench using clockwise rotation.

The pictorial chart on the preceding page is an illustration of the Universal Nose Tip™ System.

Universal Nose Tip™ is a Trademark of LOK-FAST, INC
Nose Tip™ Connector™ is a Trademark of LOK-FAST, INC



Drive-Nut Interchangeability

LOK-FAST

Dia.	Fastener	Pneumatic	Standard Right Angle	Torq. Resp. Right Angle	Close Qtr. Right Angle	Standard Hand Tool	Close Qtr. Hand Tool
-5	VLII / CLII						
-6	VLII / CLII						
-7	CLII only						
-8	VLII / CLII						
-9	CLII only						
-10	VLII / CLII						
-11	CLII only						
-12	VLII / CLII						

NOTE: VLII - represents Visu-Lok II
CLII - represents Composi-Lok II



Composi-LokII® adapter assemblies may install Visu-Lok II®

Adapter assemblies identical for both Visu-Lok II® and Composi-Lok II®

Visu-Lok II® and Composi-Lok II® fasteners have certain common driving dimensions. The drivenuts are identical for both fasteners. In the -8, -10, and -12 diameter fasteners the wrench flats are common to both fastener types. In the -5 and -6 diameters, the wrench flats are not common to Visu-Lok II® and Composi-Lok II®. Therefore, wrench adapters used to install these fasteners are not interchangeable.

The larger blind side "footprint" of Composi-Lok II® is accomplished through the use of a longer sleeve and corebolt. The close quarter installation tools permit the corebolt to pass completely through the wrench. Therefore, in the -8, -10, and -12 diameters, close quarter installation is 100% interchangeable. In all other installation tools, the corebolt does not pass completely through the wrench. The wrench adapter (and consequently, the nose adapter) must be longer to install the Composi-Lok II®

In the common wrench-flat diameters, the longer installation tooling (Composi-Lok II®) may be used to install the Visu-Lok II®, but the tooling for Visu-Lok II® may not be used for Composi-Lok II® installations.

If it is desired to standardize on one system of adapters for use with both types of fasteners, Lok-Fast provides a longer wrench adapter for the -5 and -6 Visu-Lok II® to be used with the Composi-Lok II® nose adapters.

The opposite chart illustrates the interchangeability. The two tooling systems are described in separate sections of this catalog. The new wrench adapters for Visu-Lok II® sizes -5 and -6 are contained only in the section on Visu-Lok II®. For these wrench adapters, selection of the corresponding Composi-Lok II® nose adapter is made by referring to the same page in the section on Composi-Lok tooling.



Pneumatic Pistol Driver Assembly for Visu-Lok II[®]

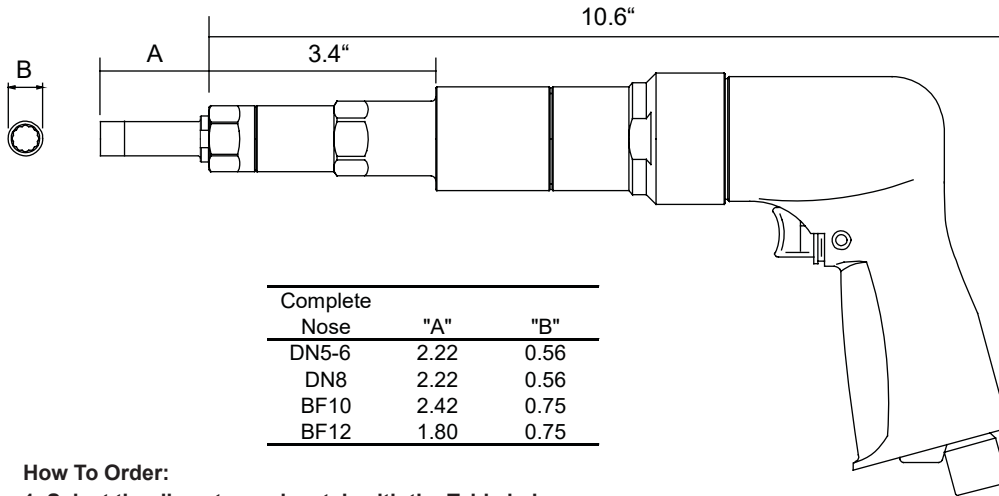

How To Order:

1. Select the diameter and match with the Table below
2. From the corresponding row select the complete assembly part number or the parts needed.

Example: DN8AA

Part Number Includes

- S540MTD Pneumatic Pistol Driver
- MTD302 Master Torque Driver
- DNC8 Nose Tip Connector
- DNUT5-6 Universal Nose Tip
- TD2601 Wrench Adapter

Dia.	Visu-Lok II Series	Complete Assembly	Pneumatic Pistol	Adapter Assembly	Complete Nose Adapt	Nose Tip Connector	Universal Nose Tip	Wrench Adapter
5/32"	PLT5000-5(-)	DN5AA		DN5A	DN5-6	DNC5-6	DNUT5-6	TD1651
3/16"	PLT5000-6(-)	DN6AA		DN6A	DN5-6	DNC5-6	DNUT5-6	TD2001
1/4"	PLT5000-8(-)	DN8AA	S540MTD	DN8A	DN8	DNC8	DNUT8	TD2601
5/16"	PLT5000-10(-)	DN10AA		DN10A	DN10	DNC10	DNUT12	TD3121
3/8"	PLT5000-12(-)	DNPT12AA		DNPT12A	DNPT12	DNCPT12	DNUT12	PT3751

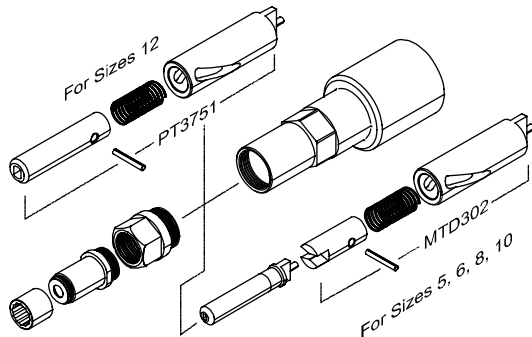

Technical Data

Operating Pressure	90 PSI
Torque Output	220 in-lbs
Motor Speed	540 rpm
Air Consumption (at free speed)	30 cfm
Horse Power Rating	0.5
Weight	3.5lb



Pneumatic Right Angle Visu-Lok II[®]

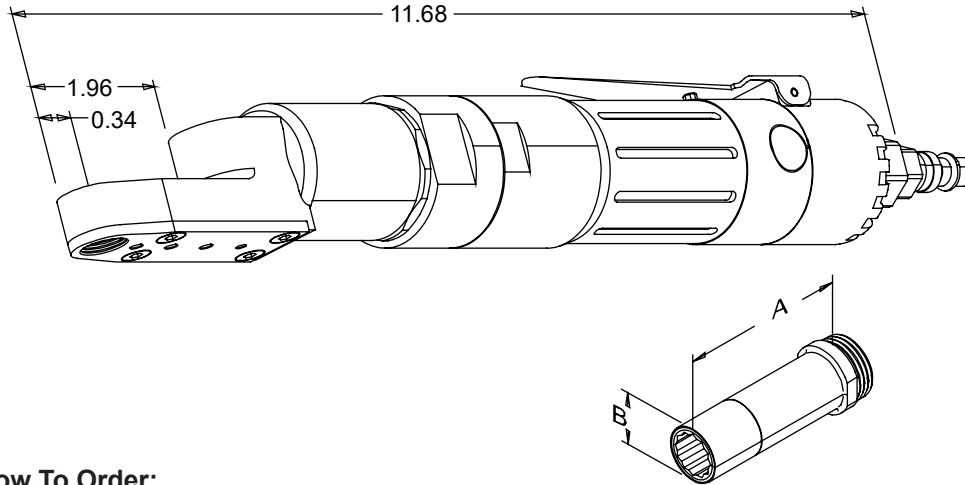

How To Order:

1. Select the diameter and match with the Table below
2. From the corresponding row select the complete assembly part number or the parts needed.

Example: DNR8AA

Part Number Includes

- 7440 Pneumatic Wrench Driver
- DNC8 Nose Tip Connector
- DNUT8 Universal Nose Tip
- PW4601 Wrench Adapter

Dia.	Visu-Lok II Series	Complete Assembly	Pneumatic Pistol	Adapter Assembly	Complete Nose Adapter	Nose Tip Connector	Universal Nose Tip	Wrench Adapter
5/32"	PLT5000-5-()	DNR5AA		DNR5A	DN5-6	DNC5-6	DNUT5-6	PW4651
3/16"	PLT5000-6-()	DNR6AA	7440	DNR6A	DN5-6	DNC5-6	DNUT5-6	PW4001
1/4"	PLT5000-8-()	DNR8AA		DNR8A	DN8	DNC8	DNUT8	PW4601
5/16"	PLT5000-10-()	DNR10AA		DNR10A	DN10	DNC10	DNUT12	PW4121

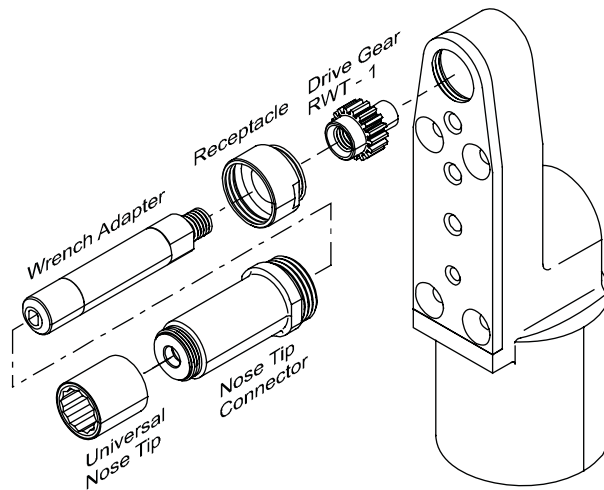

Technical Data

Operating Pressure	90 PSI
Torque Output	220 in-lbs
Motor Speed	500 rpm
Air Consumption (at free speed)	30 cfm
Horse Power Rating	0.5
Weight	3.5lb



Pneumatic Right Angle Torque Responsive Adapter Visu-Lok II[®]

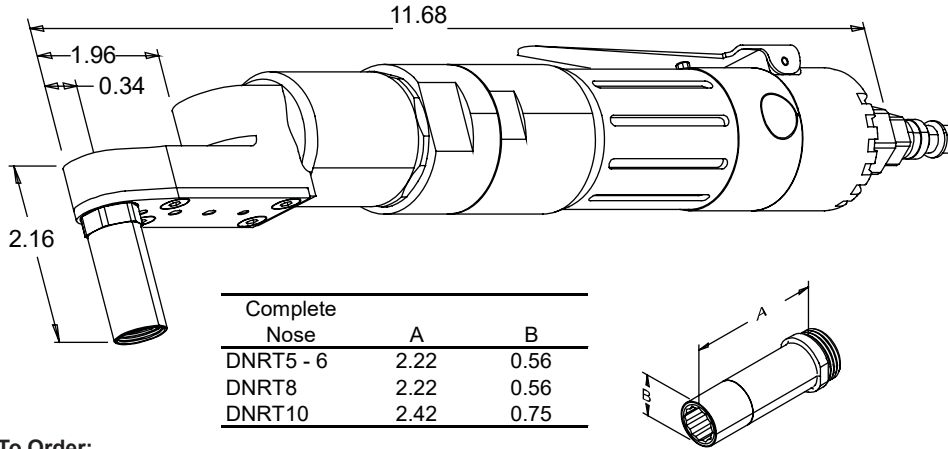

How To Order:

1. Select the diameter and match with the Table below
2. From the corresponding row select the complete assembly part number or the parts needed.

Example: DNRT5AA

Part Number Includes

- 7440M Pneumatic Wrench Driver
- DNCRT5-6 Nose Tip Connector
- DNUT5-6 Universal Nose Tip
- TD5651 Wrench Adapter

Dia.	Visu-Lok II Series	Complete Assembly	Pneumatic Pistol	Adapter Assembly	Complete Nose Adapter	Nose Tip Connector	Universal Nose Tip	Wrench Adapter
5/32"	PLT5000-5-(-)	DNRT5AA		DNRT5A	DNRT5-6	DNCRT5-6	DNUT5-6	TD5651
3/16"	PLT5000-6-(-)	DNRT6AA		DNRT6A	DNRT5-6	DNCRT5-6	DNUT5-6	TD5001
1/4"	PLT5000-8-(-)	DNRT8AA	7440M	DNRT8A	DNRT8	DNCRT8	DNUT8	TD5601
5/16"	PLT5000-10-(-)	DNRT10AA		DNRT10A	DNRT10	DNCRT10	DNUT12	TD5121

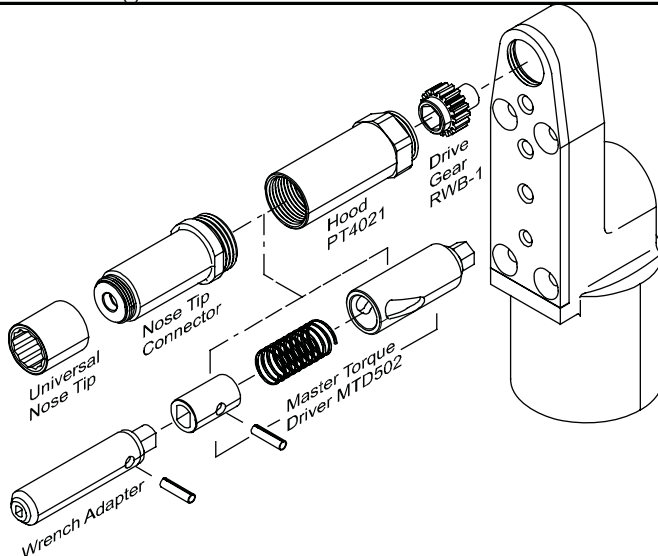

Technical Data	
Operating Pressure	90 PSI
Torque Output	220 in-lbs
Motor Speed	500 rpm
Air Consumption (at free speed)	30 cfm
Horse Power Rating	0.5
Weight	3.5lb



Pneumatic Right Angle w/ Integrated Socket Torque Responsive Adapter for Visu-Lok II®

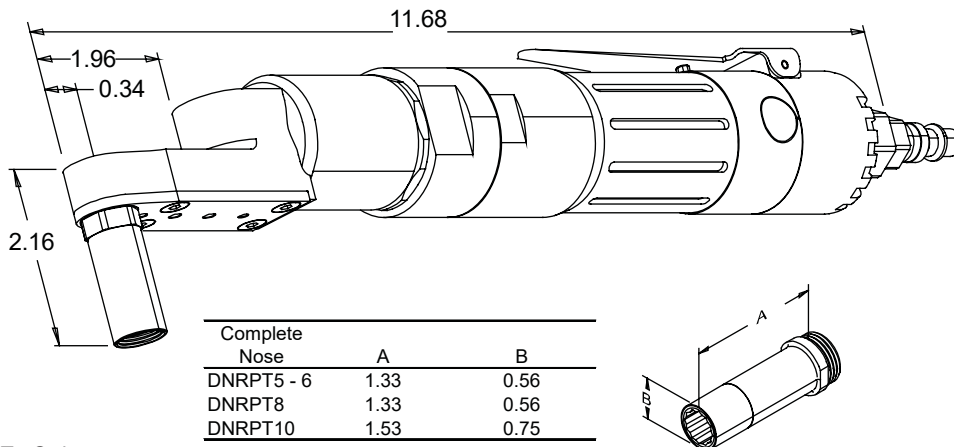

How To Order:

1. Select the diameter and match with the Table below
2. From the corresponding row select the complete assembly part number or the parts needed.

Example: DNRPT5AA

Part Number Includes

- 7440M Pneumatic Wrench Driver
- DNCRPT5-6 Nose Tip Connector
- DNUT5-6 Universal Nose Tip
- UPTRW-5 Complete Wrench/Driver
- UWT-5 Wrench Tip

Dia.	Visu-Lok II Series	Complete Assembly	Pneumatic Pistol	Adapter Assembly	Complete Nose Adapter	Nose Tip Connector	Universal Nose Tip	Wrench Adapter	Wrench Tip
5/32"	PLT5000-5-()	DNRPT5AA		DNRPT5A	DNPT5-6	DNCRPT5-6	DNUT5-6	UPTRW-5	UWT-5
3/16"	PLT5000-6-()	DNRPT6AA	7440M	DNRPT6A	DNPT5-6	DNCRPT5-6	DNUT5-6	UPTRW-6	UWT-6
1/4"	PLT5000-8-()	DNRPT8AA		DNRPT8A	DNPT8	DNCRPT8	DNUT8	UPTRW-8	UWT-8
5/16"	PLT5000-10-()	DNRPT10AA		DNRPT10A	DNPT10	DNCRPT10	DNUT12	UPTRW-10	UWT-10

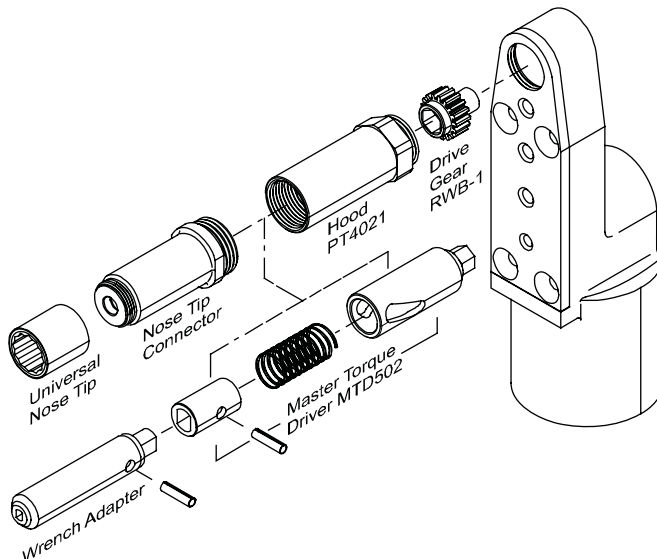

Technical Data	
Operating Pressure	90 PSI
Torque Output	220 in-lbs
Motor Speed	500 rpm
Air Consumption (at free speed)	30 cfm
Horse Power Rating	0.5
Weight	3.5lb



TOOLS ENGINEERED TO PERFORM

Pneumatic Right Angle Close Quarter Visu-Lok II®

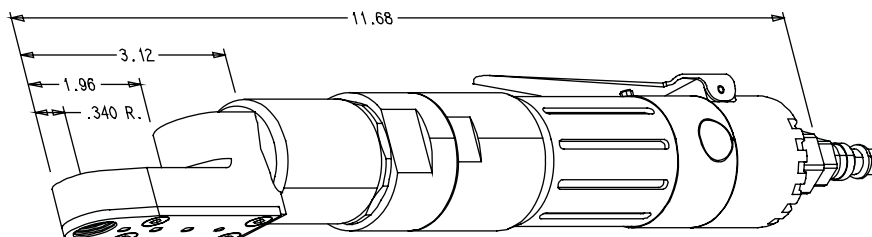

Complete Nose	A	B
DNRC5 - 6	0.53	0.56
DNRC8	0.53	0.56
DNRC10	0.73	0.75



How To Order:

1. Select the diameter and match with the Table below
2. From the corresponding row select the complete assembly part number or the parts needed.

Example: DRNRC6-AA

Part Number Includes

- 7440C Pneumatic Wrench Driver
- DNRC5-6 Nose Tip Connector
- DNUT5-6 Universal Nose Tip
- RW5-1 Wrench Gear

Dia.	Visu-Lok II Series	Complete Assembly	Pneumatic Pistol	Adapter Assembly	Complete Nose Adapter	Nose Tip Connector	Universal Nose Tip	Wrench Adapter
5/32"	PLT5000-5-(-)	DNRC5AA		DNRC5A	DNRC5-6	DNCR5-6	DNUT5-6	RW5-1
3/16"	PLT5000-6-(-)	DNRC6AA	7440C	DNRC6A	DNRC5-6	DNCR5-6	DNUT5-6	RW6-1
1/4"	PLT5000-8-(-)	DNRC8AA		DNRC8A	DNRC8	DNCR8	DNUT8	RW8-1
5/16"	PLT5000-10-(-)	DNRC10AA		DNRC10A	DNRC10	DNCR10	DNUT12	RW10-1

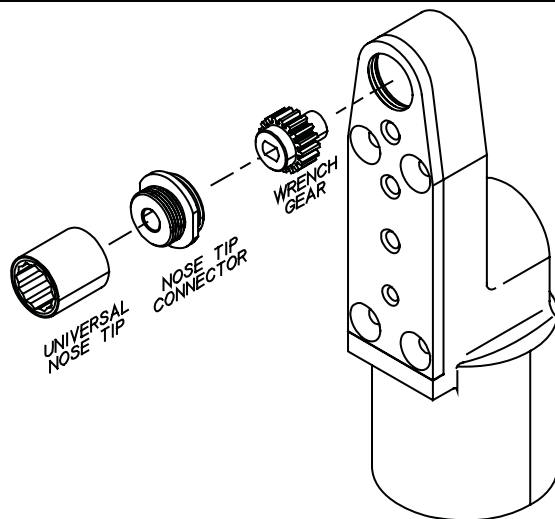

Technical Data	
Operating Pressure	90 PSI
Torque Output	220 in-lbs
Motor Speed	500 rpm
Air Consumption (at free speed)	30 cfm
Horse Power Rating	0.5
Weight	3.5lb



Ratchet Hand Tool for Visu-Lok II®

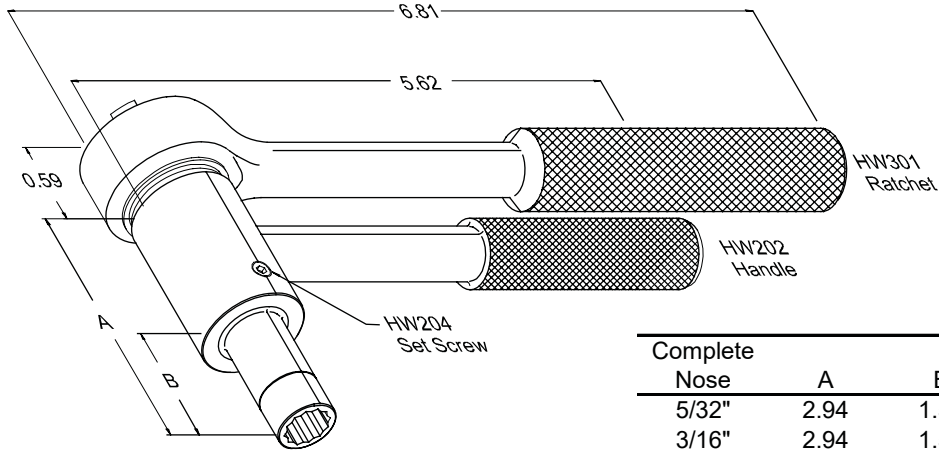

Complete Nose	A	B	C
5/32"	2.94	1.50	0.56
3/16"	2.94	1.50	0.56
7/32"	3.07	1.62	0.56
1/4"	3.07	1.62	0.56
5/16"	3.14	1.70	0.75
3/8"	3.16	1.72	0.75

How To Order:

1. Select the diameter and match with the Table on this page.
2. From the corresponding row select the complete assembly part number or the parts needed.

Example: DNH5AA

Part Number Includes

- HW300 Ratchet Wrench
- HW202 Holder
- DNCH5-6 Nose Tip Connector
- DNUT5-6 Universal Nose Tip
- HW1651 Wrench Gear

Dia.	Visu-Lok II Series	Complete Assembly	Ratchet Wrench	Adapter Assembly	Complete Nose Adapter	Nose Tip Connector	Universal Nose Tip	Wrench Adapter
5/32"	PLT5000-5-()	DNH5AA		DNH5A	DNH5-6	DNCH5-6	DNUT5-6	HW1651
3/16"	PLT5000-6-()	DNH6AA		DNH6A	DNH5-6	DNCH5-6	DNUT5-6	HW2001
1/4"	PLT5000-8-()	DNH8AA	HW300	DNH8A	DNH8	DNCH8	DNUT8	HW2601
5/16"	PLT5000-10-()	DNH10AA		DNH10A	DNH10	DNCH10	DNUT12	HW3121
3/8"	PLT5000-12-()	DNH12AA		DNH12A	DNH12	DNCH12	DNUT12	HW3751

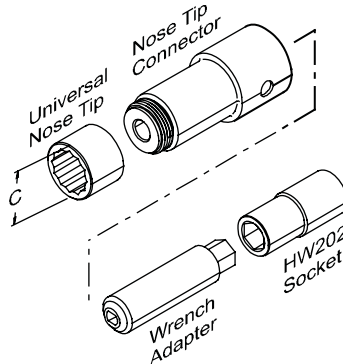



Ratchet Hand Tool Close Quarter for Visu-Lok II®



Complete Nose	"A"	"B"	"C"
5/32"	0.65	0.51	0.56
3/16"	0.65	0.51	0.56
7/32"	0.80	0.46	0.56
1/4"	0.80	0.46	0.56
5/16"	0.80	0.67	0.75
3/8"	0.80	0.67	0.75

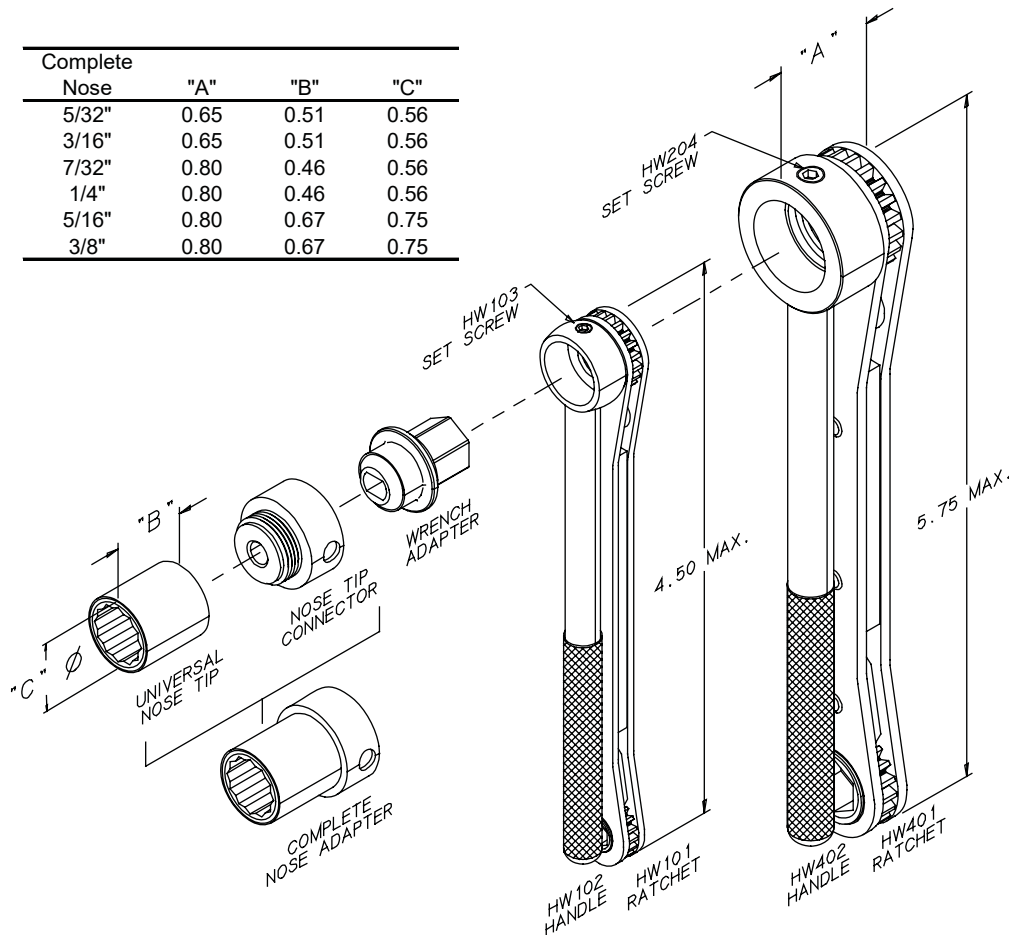

How To Order:

1. Select the diameter and match with the Table on this page.
2. From the corresponding row select the complete assembly part number or the parts needed.

Example: DNHC5AA

Part Number Includes

- HW100 Ratchet Wrench
- HW102 Holder
- DNHC5-6 Nose Tip Connector
- DNUT5-6 Universal Nose Tip
- HW5 Wrench Gear

Dia.	Visu-Lok II Series	Complete Assembly	Pneumatic Adapter Pistol	Pneumatic Adapter Assembly	Complete Nose Adapter	Nose Tip Connector	Universal Nose Tip	Wrench Adapter
5/32"	PLT5000-5-(-)	DNHC5AA	HW 100	DNHC5A	DNHC5-6	DNCHC5-6	DNUT5-6	HW5
3/16"	PLT5000-6-(-)	DNHC6AA	HW 100	DNHC6A	DNHC5-6	DNCHC5-6	DNUT5-6	HW6
1/4"	PLT5000-8-(-)	DNHC8AA	HW 400	DNHC8A	DNHC8	DNCHC8	DNUT8	HW8
5/16"	PLT5000-10-(-)	DNHC10AA	HW 400	DNHC10A	DNHC12	DNCHC12	DNUT12	HW10
3/8"	PLT5000-12-(-)	DNHC12AA	HW 400	DNHC12A	DNHC12	DNCHC12	DNUT12	HW12



Visu-Lok II[®]
Grip Scales



Grip Scale Part #: LFVLG-1

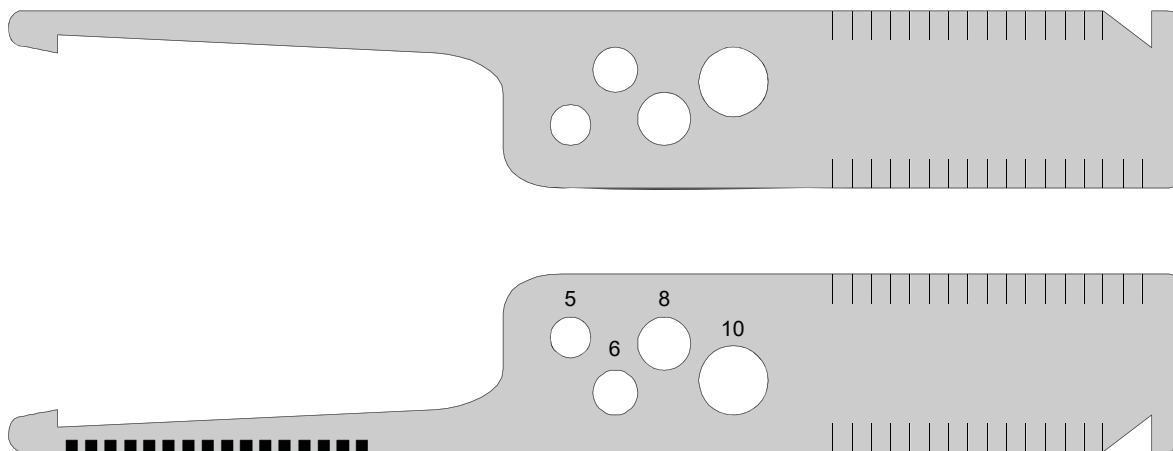

Selection of Grip Length

In measuring hole depth take reading where the skin surface meets the number or line on gauge. If directly on a line use either the indicated grip or the next longer grip.

In cases where there a tapered sheet condition exists, determine grip length at the hole centerline. The taper must not exceed 7° to ensure the proper performance of the fastener.

ZEPHYR[®]
T O O L
G R O U P



TOOLS ENGINEERED TO PERFORM



LOK-FAST

ZEPHYR TOOL GROUP

201 Hindry Avenue
Inglewood, CA 90301
Tel. 310-410-4907 ■ Email: sales@zephyrtoolgroup.com ■ zephyrtoolgroup.com

ZEPHYR[®]
TOOL
GROUP



TOOLS ENGINEERED TO PERFORM



LOK-FAST

Composi-Lok II Blind Fastener Tools

ZEPHYR TOOL GROUP

201 Hindry Avenue
Inglewood, CA 90301

Tel. 310-410-4907 ▪ Email: sales@zephyrtoolgroup.com ▪ zephyrtoolgroup.com



Universal Nose Tip™ System for Installing Drive-Nut Type



Driver Model #	Universal Nose Tip	Nose Tip Connector	Wrench Adapter	Torque Driver
S540MTD / S540MTD-BF Pneumatic Pistol				
7440 - 90° Right Angle Driver				
7440M / 7440M-BF 90° Pneumatic Torque Responsive				
7440M / 7440M-BF Integrated Wrench / Torque Driver				
7440C Close Quarter 90° Right Angle				
HW200 / HW300 Standard Ratchet Hand Tool				
HW100 / HW400 Close Quarter Ratchet Hand Tool				

Universal Interchangeable Nose Tips

Installation tools have been simplified in the "DRIVE NUT" fastener system in both Visu-Lok II® and Composi-Lok II®

LOK-FAST has further simplified the tooling with UNIVERSAL NOSE TIP™. Now, for a given size range any nose tip may be interchangeable with any driver.

An installation tool consists of a driver and an adapter assembly. The adapter assembly is comprised of a nose adapter to engage the corebolt through rotation to clamp-up and break-off. In most cases, for a given driver, the LOK-FAST UNIVERSAL NOSE TIP™ SYSTEM uses only three complete nose adapters for all the fastener head styles, and for the complete range of sizes from 5/32" to 3/8".

Two Part Nose Adapter

The nose adapter is now a two piece design consisting of the Universal Nose Tip™ and the Nose Tip Connector™. The nose tip engages the fastener drivenut, and the nose tip is threaded onto the connector to form a complete installation tool. The two piece design allows interchanging of the nose tips among all driver configurations and further allows interchangeability between Visu-Lok II® and Composi-Lok II® installation tools. The nose tip may be removed with a standard allen wrench using clockwise rotation.

The pictorial chart on the preceding page is an illustration of the Universal Nose Tip™ System.

Universal Nose Tip™ is a Trademark of LOK-FAST, INC
Nose Tip™ Connector™ is a Trademark of LOK-FAST, INC



Drive-Nut Interchangeability



Dia.	Fastener	Pneumatic	Standard Right Angle	Torq. Resp. Right Angle	Close Qtr. Right Angle	Standard Hand Tool	Close Qtr. Hand Tool
-5	VLII / CLII						
-6	VLII / CLII						
-7	CLII only						
-8	VLII / CLII						
-9	CLII only						
-10	VLII / CLII						
-11	CLII only						
-12	VLII / CLII						

NOTE: VLII - represents Visu-Lok II
CLII - represents Composi-Lok II



Composi-LokII® adapter assemblies may install Visu-Lok II®

Adapter assemblies identical for both Visu-Lok II® and Composi-Lok II®

Visu-Lok II® and Composi-Lok II® fasteners have certain common driving dimensions. The drivenuts are identical for both fasteners. In the -8, -10, and -12 diameter fasteners the wrench flats are common to both fastener types. In the -5 and -6 diameters, the wrench flats are not common to Visu-Lok II® and Composi-Lok II®. Therefore, wrench adapters used to install these fasteners are not interchangeable.

The larger blind side "footprint" of Composi-Lok II® is accomplished through the use of a longer sleeve and corebolt. The close quarter installation tools permit the corebolt to pass completely through the wrench. Therefore, in the -8, -10, and -12 diameters, close quarter installation is 100% interchangeable. In all other installation tools, the corebolt does not pass completely through the wrench. The wrench adapter (and consequently, the nose adapter) must be longer to install the Composi-Lok II®

In the common wrench-flat diameters, the longer installation tooling (Composi-Lok II®) may be used to install the Visu-Lok II®, but the tooling for Visu-Lok II® may not be used for Composi-Lok II® installations.

If it is desired to standardize on one system of adapters for use with both types of fasteners, Lok-Fast provides a longer wrench adapter for the -5 and -6 Visu-Lok II® to be used with the Composi-Lok II® nose adapters.

The opposite chart illustrates the interchangeability. The two tooling systems are described in separate sections of this catalog. The new wrench adapters for Visu-Lok II® sizes -5 and -6 are contained only in the section on Visu-Lok II®. For these wrench adapters, selection of the corresponding Composi-Lok II® nose adapter is made by referring to the same page in the section on Composi-Lok tooling.



Pneumatic Pistol Driver Assembly for Composit-Lok II®

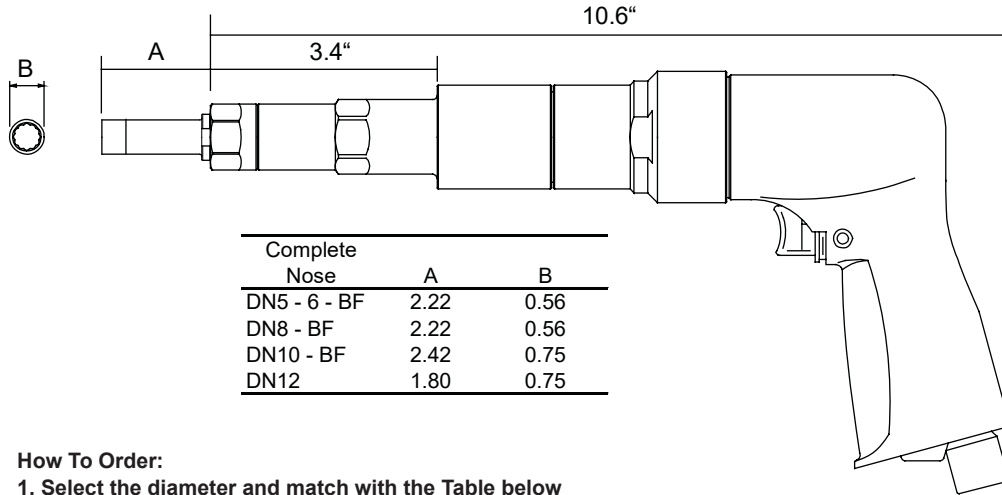

How To Order:

1. Select the diameter and match with the Table below
2. From the corresponding row select the complete assembly part number or the parts needed.

Example: DN8AA-BF

Part Number Includes

- S540MTD-BF Pneumatic Pistol Driver
- MTD302 Master Torque Driver
- DNC8-BF Nose Tip Connector
- DNUT8 Universal Nose Tip
- TD2601-BF Wrench Adapter

Dia.	Fastener Size	Complete Assembly	Adapter Assembly	Nose Adapter	Nose Tip Connector	Universal Nose Tip	Wrench Adapter
5/32"	5-()	DN5AA-BF	DN5A-BF	DN5-6-BF	DNC5-6-BF	DNUT5-6	TD1651-BF
3/16"	6-()	DN6AA-BF	DN6A-BF	DN5-6-BF	DNC5-6-BF	DNUT5-6	TD2001-BF
7/32"	7-()	DN7AA-BF	DN7A-BF	DN8-BF	DNC8-BF	DNUT8	TD7-BF
1/4"	8-()	DN8AA-BF	DN8A-BF	DN8-BF	DNC8-BF	DNUT8	TD2601-BF
9/32"	9-()	DN10AA-BF	DN10A-BF	DN10-BF	DNC10-BF	DNUT12	TD3121-BF
5/16"	10-()	DNPT10AA-BF	DNPT10A-BF	DNPT12	DNCPT12	DNUT12	PT10-BF
11/32"	11-()	DN12AA-BF	DNPT12A-BF	DNPT12	DNCPT12	DNUT12	PT12-BF
3/8"	12-()	DN12AA-BF	DNPT12A-BF	DNPT12	DNCPT12	DNUT12	PT12-BF

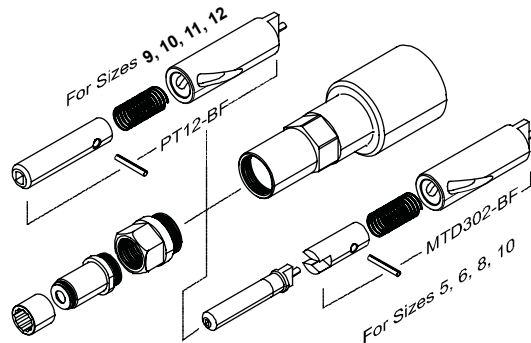

Technical Data

Operating Pressure	90 PSI
Torque Output	220 in-lbs
Motor Speed	540 rpm
Air Consumption (at free speed)	30 cfm
Horse Power Rating	0.5
Weight	3.5lb



Pneumatic Right Angle Composi-Lok II®

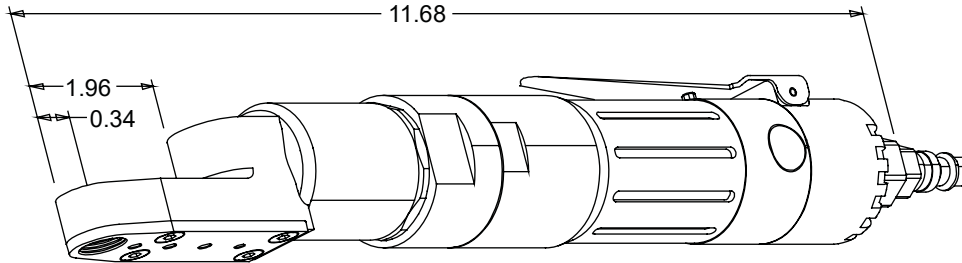

Complete Nose	A	B
DN5 - 6 - BF	2.22	0.56
DN8 - BF	2.22	0.56
DN10 - BF	2.42	0.75

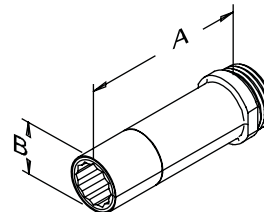

How To Order:

1. Select the diameter and match with the Table below
2. From the corresponding row select the complete assembly part number or the parts needed.

Example: DNR8AA-BF

Part Number Includes

- 7440 Pneumatic Wrench Driver
- DNC8-BF Nose Tip Connector
- DNUT8 Universal Nose Tip
- PW4602-BF Wrench Adapter

Dia.	Fastener Assembly	Complete Assembly	Adapter Assembly	Nose Adapter	Nose Tip Connector	Universal Nose Tip	Wrench Adapter
5/32"	5-()	DNR5AA-BF	DNR5A-BF	DN5-6-BF	DNC5-6-BF	DNUT5-6	PW4651-BF
3/16"	6-()	DNR6AA-BF	DNR6A-BF	DN5-6-BF	DNC5-6-BF	DNUT5-6	PW4001-BF
7/32"	7-()	DNR7AA-BF	DNR7A-BF	DN8-BF	DNC8-BF	DNUT8	PW4201-BF
1/4"	8-()	DNR8AA-BF	DNR8A-BF	DN8-BF	DNC8-BF	DNUT8	PW4601-BF
9/32"	9-()	DNR10AA-BF	DNR10A-BF	DN10-BF	DNC10-BF	DNUT12	PW4121-BF
5/16"	10-()	DNR10AA-BF	DNR10A-BF	DN10-BF	DNC10-BF	DNUT12	PW4121-BF

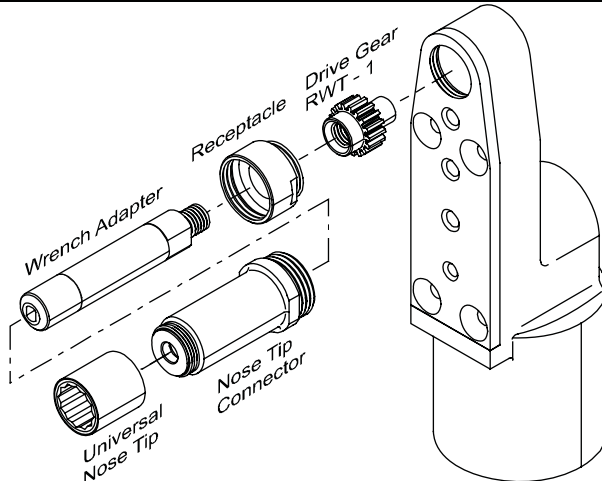

Technical Data

Operating Pressure	90 PSI
Torque Output	220 in-lbs
Motor Speed	500 rpm
Air Consumption (at free speed)	30 cfm
Horse Power Rating	0.5
Weight	3.5lb



Pneumatic Right Angle Torque Responsive Adapter Assemblies for Composi-Lok II®

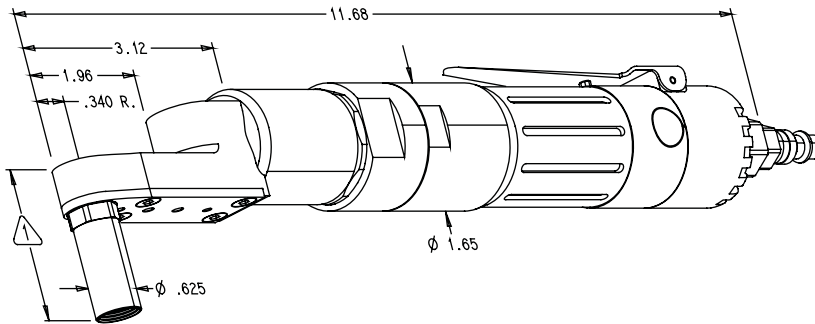

Complete Nose	"A"	"B"
DNRT5 - 6 - BF	2.22	0.56
DNRT8 - BF	2.22	0.56
DNRT10 - BF	2.42	0.75

How To Order: 2.155 - 7440M
2.615 - 7440M-BF

1. Select the diameter and match with the Table below
2. From the corresponding row select the complete assembly part number or the parts needed.

Example: DNRT7AA-BF

Part Number Includes

- 7440M-BF Pneumatic Wrench Driver
- DNCRT8-BF Nose Tip Connector
- DNUT5-6 Universal Nose Tip
- TD5201-BF Wrench Adapter

Dia.	Fastener Size	Complete Assembly	Adapter Assembly	Nose Adapter	Nose Tip Connector	Universal Nose Tip	Wrench Adapter
5/32"	5-()	DNRT5AA-BF	DNRT5A-BF	DNRT5-6-BF	DNCRT5-6-BF	DNUT5-6	TD5651-BF
3/16"	6-()	DNRT6AA-BF	DNRT6A-BF	DNRT5-6-BF	DNCRT5-6-BF	DNUT5-6	TD5001-BF
7/32"	7-()	DNRT7AA-BF	DNRT7A-BF	DNRT8-BF	DNCRT8-BF	DNUT8	TD5201-BF
1/4"	8-()	DNRT8AA-BF	DNRT8A-BF	DNRT8-BF	DNCRT8-BF	DNUT8	TD5601-BF
9/32"	9-()	DNRT10AA-BF	DNRT10A-BF	DNRT10-BF	DNCRT10-BF	DNUT12	TD5121-BF
5/16"	10-()	DNRT10AA-BF	DNRT10A-BF	DNRT10-BF	DNCRT10-BF	DNUT12	TD5121-BF

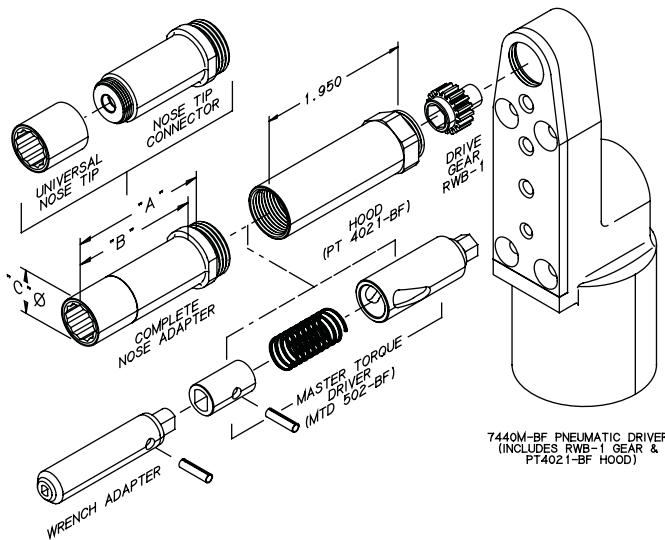

7440M-BF PNEUMATIC DRIVER (INCLUDES RWB-1 GEAR & PT402-1-BF HOOD)

Technical Data	
Operating Pressure	90 PSI
Torque Output	220 in-lbs
Motor Speed	500 rpm
Air Consumption (at free speed)	30 cfm
Horse Power Rating	0.5
Weight	3.5lb



Pneumatic Right Angle Torque Responsive with Integrated Wrench/Torque Driver for Composi-Lok II®

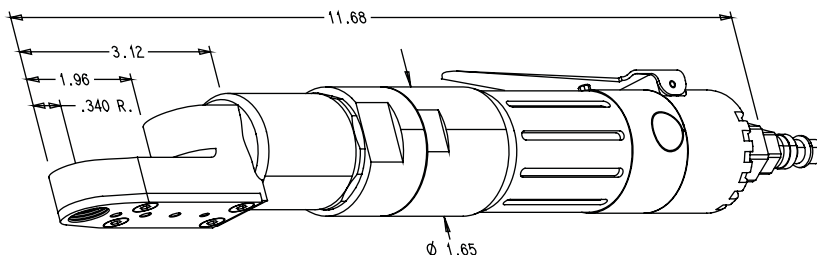

Complete Nose	"A"	"B"
DNRPT5-6-BF	1.33	0.56
DNRPT8-BF	1.33	0.56
DNRPT10-BF	1.53	0.75

How To Order:

1. Select the diameter and match with the Table below
2. From the corresponding row select the complete assembly part number or the parts needed.

Example: DNRPT10AA-BF

Part Number Includes

- 7440M-BF Pneumatic Wrench Driver
- DNCRPT10-BF Nose Tip Connector
- DNUT12 Universal Nose Tip
- UPTRW-10-BF Complete Wrench/Driver
- UWT-10 Wrench Tip

Dia.	Fastener Size	Complete Assembly	Adapter Assembly	Nose Adapter	Nose Tip Connector	Universal Nose Tip	Wrench Adapter	Wrench Tip
5/32"	5-()	DNRPT5AA-BF	DNRPT5A-BF	DNRPT5-6-BF	DNCRPT5-6-BF	DNUT5-6	UPTRW-5-BF	UWT-5-BF
3/16"	6-()	DNRPT6AA-BF	DNRPT6A-BF	DNRPT5-6-BF	DNCRPT5-6-BF	DNUT5-6	UPTRW-6-BF	UWT-6-BF
7/32"	7-()	DNRPT7AA-BF	DNRPT7A-BF	DNRPT8-BF	DNCRPT8-BF	DNUT8	UPTRW-7-BF	UWT-7-BF
1/4"	8-()	DNRPT8AA-BF	DNRPT8A-BF	DNRPT8-BF	DNCRPT8-BF	DNUT8	UPTRW-8-BF	UWT-8-BF
5/16"	10-()	DNRPT10AA-BF	DNRPT10A-BF	DNRPT10-BF	DNCRPT10-BF	DNUT12	UPTRW-10-BF	UWT-10-BF

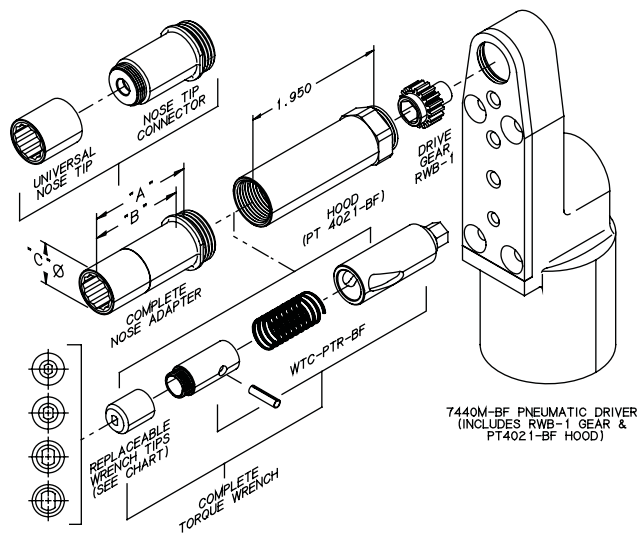

Technical Data	
Operating Pressure	90 PSI
Torque Output	220 in-lbs
Motor Speed	500 rpm
Air Consumption	30 cfm
(at free speed)	
Horse Power Rating	0.5
Weight	3.5lb



Pneumatic Right Angle Close Quarter Driver Assemblies for Composi-Lok II[®]

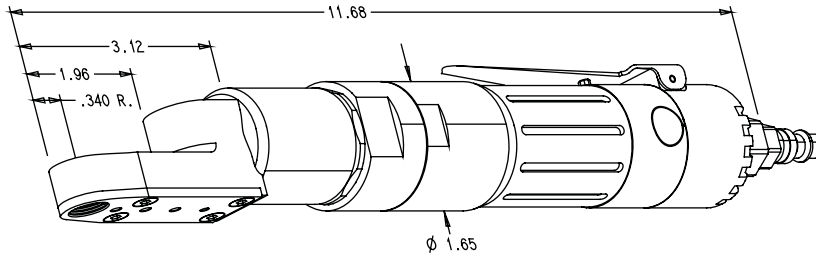

Complete Nose	"A"	"B"
DNRC5-6-BF	0.53	0.56
DNRC8-BF	0.53	0.56
DNRC10-BF	0.73	0.75

How To Order:

1. Select the diameter and match with the Table below
2. From the corresponding row select the complete assembly part number or the parts needed.

Example: DNRC5AA-BF

Part Number Includes

- 7440C Pneumatic Wrench Driver
- DNCR5-6 Nose Tip Connector
- DNUT5-6 Universal Nose Tip
- RW5-1-BF Wrench Gear

Dia.	Fastener Size	Complete Assembly	Adapter Assembly	Nose Adapter	Nose Tip Connector	Universal Nose Tip	Wrench Adapter
5/32"	5-()	DNRC5AA-BF	DNRC5A-BF	DNRC5-6	DNCRC5-6	DNUT5-6	RW5-1-BF
3/16"	6-()	DNRC6AA-BF	DNRC6A-BF	DNRC5-6	DNCRC5-6	DNUT5-6	RW6-1-BF
7/32"	7-()	DNRC7AA-BF	DNRC7A-BF	DNRC8	DNCRC-8	DNUT8	RW7-1-BF
1/4"	8-()	DNRC8AA-BF	DNRC8A	DNRC8	DNCRC-8	DNUT8	RW8-1
9/32"	9-()	DNRC10AA	DNRC10A	DNRC10	DNCRC-10	DNUT12	RW10-1
5/16"	10-()	DNRC10AA	DNRC10A	DNRC10	DNCRC-10	DNUT12	RW10-1

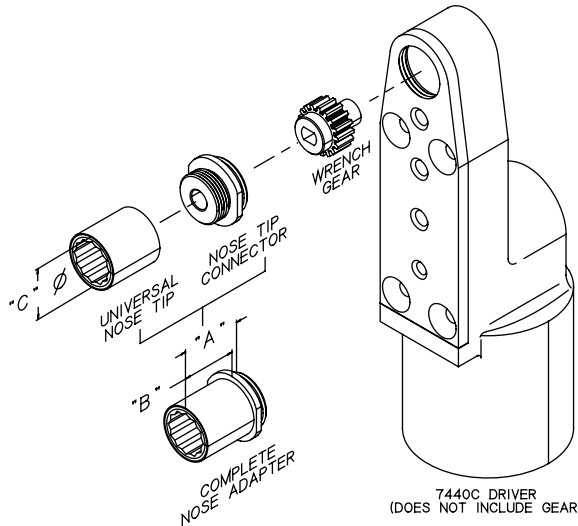

Technical Data

Operating Pressure	90 PSI
Torque Output	220 in-lbs
Motor Speed	500 rpm
Air Consumption (at free speed)	30 cfm
Horse Power Rating	0.5
Weight	3.5lb



Standard Ratchet Hand Tool Adapter Assembly for Composi-Lok II®



Nose	"A"	"B"
5/32"	2.94	0.56
3/16"	2.94	0.56
7/32"	3.07	0.56
1/4"	3.07	0.56
5/16"	3.14	0.75
3/8"	3.16	0.75

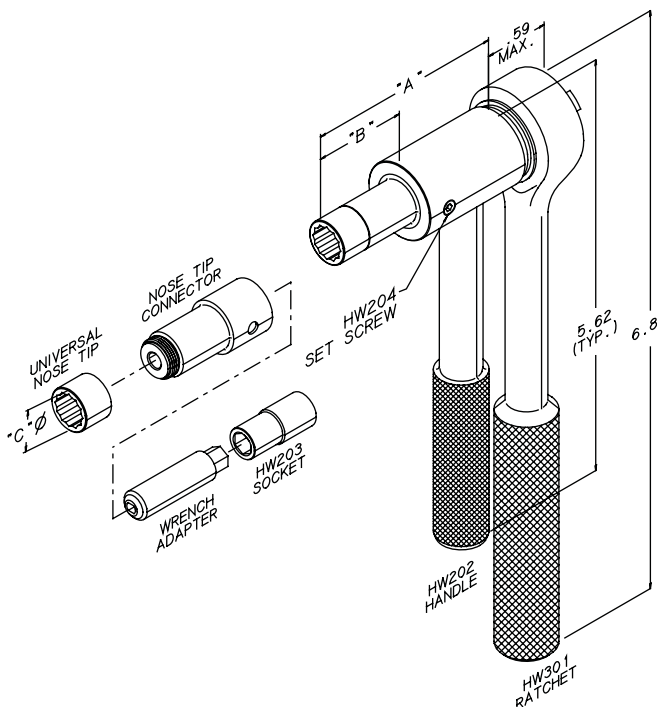

How To Order:

1. Select the diameter and match with the Table on this page.
2. From the corresponding row select the complete assembly part number or the parts needed.

Example: DNH5AA-BF

Part Number Includes

- HW301 Ratchet Wrench
- HW202 Holder
- DNCH5-6-BF Nose Tip Connector
- DNUT5-6 Universal Nose Tip
- HW1651-BF Wrench Gear

Dia.	Fastener Size	Complete Assembly	Adapter Assembly	Nose Adapter	Nose Tip Connector	Universal Nose Tip	Wrench Adapter
5/32"	5-()	DNH5AA-BF	DNH5A-BF	DNH5-6-BF	DNCH5-6-BF	DNUT5-6	HW1651-BF
3/16"	6-()	DNH6AA-BF	DNH6A-BF	DNH5-6-BF	DNCH5-6-BF	DNUT5-6	HW2001-BF
7/32"	7-()	DNH7AA-BF	DNH7A-BF	DNH8-BF	DNCH8-BF	DNUT8	HW2201-BF
1/4"	8-()	DNH8AA-BF	DNH8A-BF	DNH8-BF	DNCH8-BF	DNUT8	HW2601-BF
9/32"	9-()	DNH10AA-BF	DNH10A-BF	DNH12-BF	DNCH12-BF	DNUT12	HW3121-BF
5/16"	10-()	DNH10AA-BF	DNH10A-BF	DNH12-BF	DNCH12-BF	DNUT12	HW3121-BF
11/32"	11-()	DNH12AA-BF	DNH12A-BF	DNH12-BF	DNCH12-BF	DNUT12	HW3751-BF
3/8"	12-()	DNH12AA-BF	DNH12A-BF	DNH12-BF	DNCH12-BF	DNUT12	HW3751-BF



Close Quarter Ratchet Hand Tool Adapter Assemblies for Composi-Lok II®



Nose	"A"	"B"
DNHC5-6	0.65	0.56
DNHC8	0.80	0.56
DNHC12	0.80	0.75

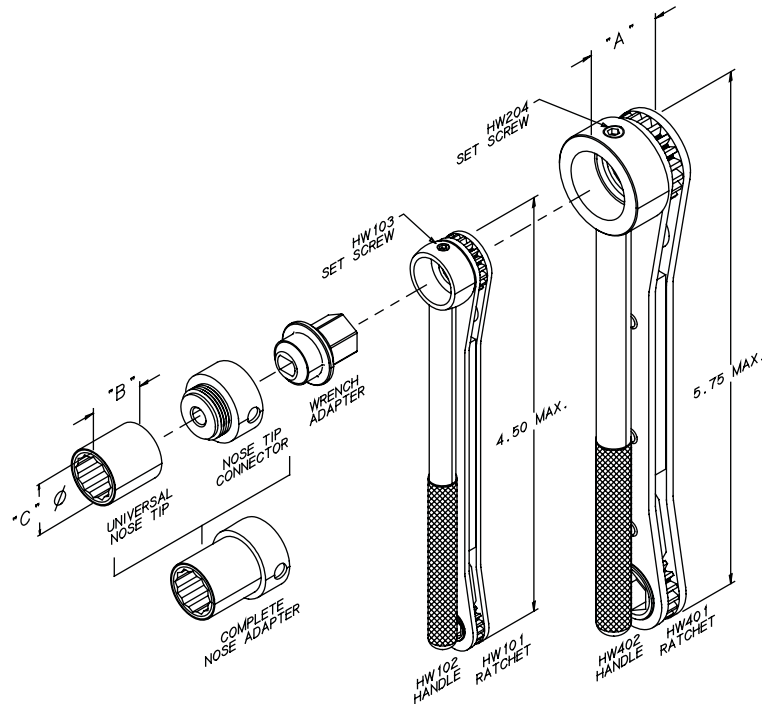

How To Order:

1. Select the diameter and match with the Table on this page.
2. From the corresponding row select the complete assembly part number or the parts needed.

Example: DNHC5AA-BF

Part Number Includes

- HW101 Ratchet Wrench
- HW102 Holder
- DNHC5-6 Nose Tip Connector
- DNUT5-6 Universal Nose Tip
- HW5-BF Wrench Gear

Dia.	Fastener Size	Complete Assembly	Ratchet Driver	Adapter Assembly	Nose Adapter	Nose Tip Connector	Universal Nose Tip	Wrench Adapter
5/32"	5-()	DNHC5AA-BF	HW100	DNHC5A-BF	DNHC5-6	DNCHC5-6	DNUT5-6	HW5-BF
3/16"	6-()	DNHC6AA-BF	HW100	DNHC6A-BF	DNHC5-6	DNCHC5-6	DNUT5-6	HW6-BF
7/32"	7-()	DNHC7AA-BF	HW400	DNHC7A-BF	DNHC8	DNCHC8	DNUT8	HW7-BF
1/4"	8-()	DNHC8AA	HW400	DNHC8A	DNHC8	DNCHC8	DNUT8	HW8
9/32"	9-()	DNHC10AA	HW400	DNHC10A	DNHC12	DNCHC12	DNUT12	HW10
5/16"	10-()	DNHC10AA	HW400	DNHC10A	DNHC12	DNCHC12	DNUT12	HW10
11/32"	11-()	DNHC12AA	HW400	DNHC12A	DNHC12	DNCHC12	DNUT12	HW12
3/8"	12-()	DNHC12AA	HW400	DNHC12A	DNHC12	DNCHC12	DNUT12	HW12



Grip Scales for Composi-Lok® and Composi-Lok II® Fasteners



Grip Scale Part #: LFCLG-1 & LFCLG-2

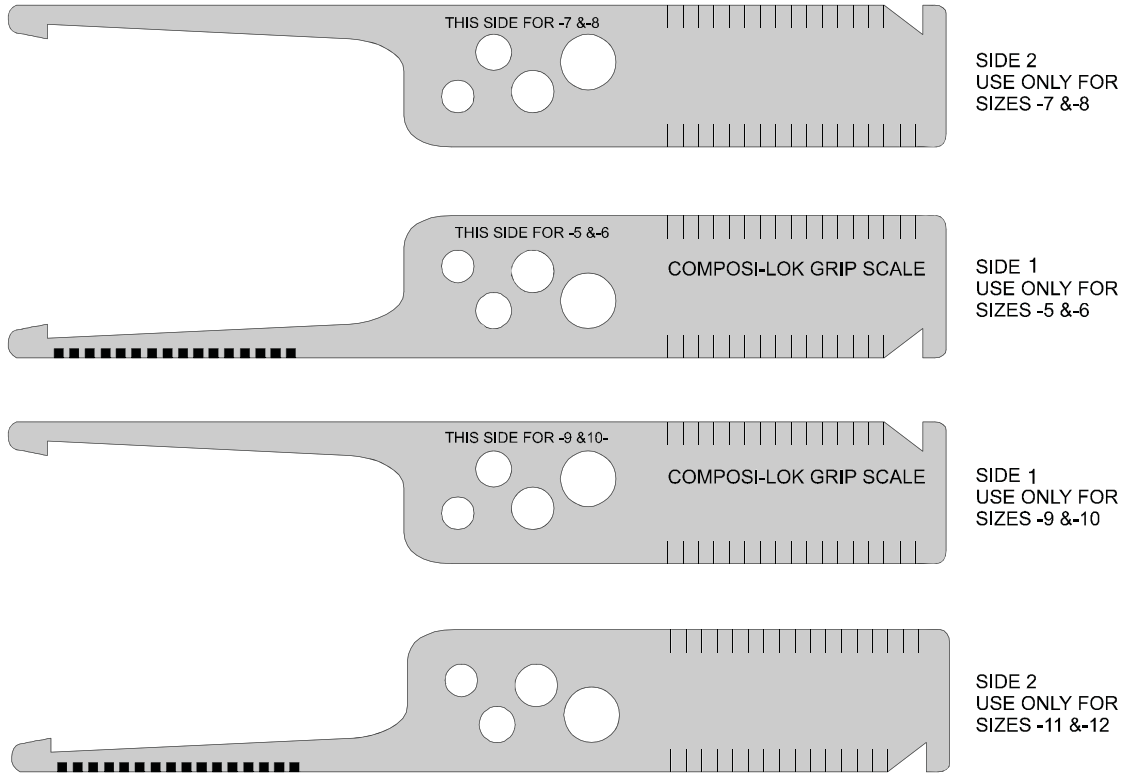

Selection of Grip Length

In measuring hole depth take reading where the skin surface meets the number or line on gauge. If directly on a line use either the indicated grip or the next longer grip.

In cases where there a tapered sheet condition exists, determine grip length at the hole centerline. The taper must not exceed 7° to ensure the proper performance of the fastener.

ZEPHYR[®]
TOOL
GROUP



TOOLS ENGINEERED TO PERFORM



LOK-FAST

ZEPHYR TOOL GROUP

201 Hindry Avenue
Inglewood, CA 90301

Tel. 310-410-4907 ■ Email: sales@zephyrtoolgroup.com ■ zephyrtoolgroup.com

ZEPHYR[®]
T O O L
G R O U P



TOOLS ENGINEERED TO PERFORM

ZEPHYR[®]
SCREWDRIVING TOOLS

KWIK-LOK[™]
TEMPORARY FASTENERS

ZEPHYR[®]
AEROSPACE HAND & PNEUMATIC TOOLS

LOK-FAST[™]
AEROSPACE FASTENER TOOLS

Martin[™]
AIRCRAFT TOOL

LOK-FAST

Composi-Lok 3

Blind Fastener Tools

ZEPHYR TOOL GROUP

201 Hindry Avenue
Inglewood, CA 90301

Tel. 310-410-4907 ■ Email: sales@zephyrtoolgroup.com ■ zephyrtoolgroup.com

Page 49
07/16



Pneumatic Pistol Driver Assembly for Composi-Lok 3

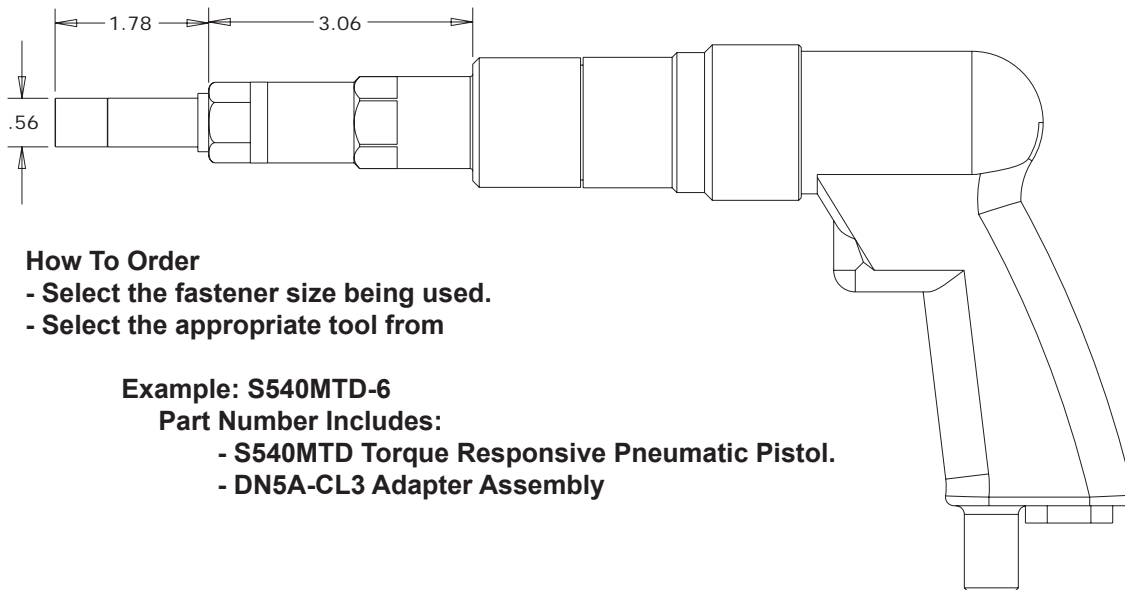

How To Order

- Select the fastener size being used.
- Select the appropriate tool from

Example: S540MTD-6

Part Number Includes:

- S540MTD Torque Responsive Pneumatic Pistol.
- DN5A-CL3 Adapter Assembly

Dia.	Composi-Lok 3 Series	Complete Assembly	Pneumatic Pistol	Adapter Assembly	Complete Nose Adapter	Nose Tip Connector	Universal Nose Tip	Wrench Adapter
5/32"		DN5AA-CL3		DN5A-CL3	DN5-8-CL3	DNC5-6	DNUT5-8-CL3	TD1651-CL3
3/16"	MBF2300	DN6AA-CL3	S540MTD	DN6A-CL3	DN5-8-CL3	DNC5-6	DNUT5-8-CL3	TD2001-CL3
1/4"		DN8AA-CL3		DN8A-CL3	DN5-8-CL3	DNC8	DNUT5-8-CL3	TD2601-CL3

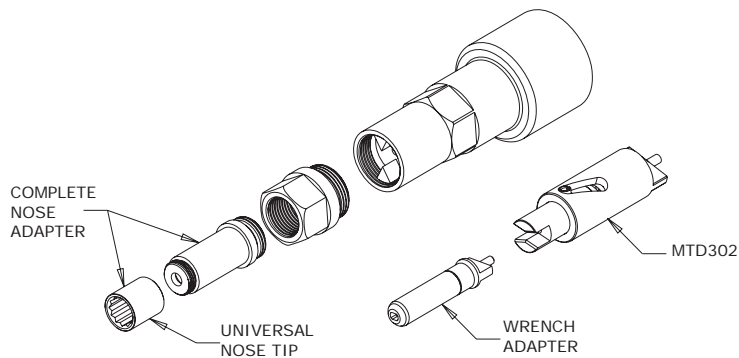

Technical Data

Operating Pressure	90 PSI
Torque Output	220 in-lbs
Motor Speed	500 rpm
Air Consumption (at free speed)	30 cfm
Horse Power Rating	0.5
Weight	3.5lb



Pneumatic Right Angle Assembly for Composi-Lok 3

How To Order

- Select the fastener size being used.
- Select the appropriate tool from Table below



Example: DNR5AA-CL3

Part Number Includes

- 7440 Pneumatic Right Angle Motor.
- DNR5A-CL3 Driver Assembly.

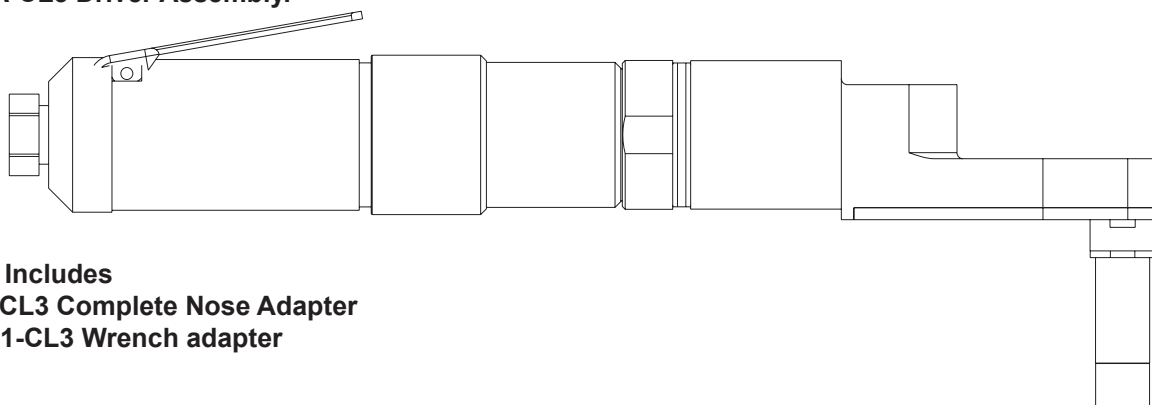

DNR5A-CL3

Part Number Includes

- DN5-8-CL3 Complete Nose Adapter
- PW4651-CL3 Wrench adapter

Dia.	Composi-Lok 3 Series	Complete Assembly	Pneumatic Pistol	Adapter Assembly	Complete Nose Adapter	Nose Tip Connector	Universal Nose Tip	Wrench Adapter
5/32"		DNR5AA-CL3		DNR5A-CL3	DN5-8-CL3	DNC5-6	DNUT5-8-CL3	PW4651-CL3
3/16"	MBF2300	DNR6AA-CL3	7440.	DNR6A-CL3	DN5-8-CL3	DNC5-6	DNUT5-8-CL3	PW4001-CL3
1/4"		DNR8AA-CL3		DNR8A-CL3	DN5-8-CL3	DNC8	DNUT5-8-CL3	PW4601-CL3

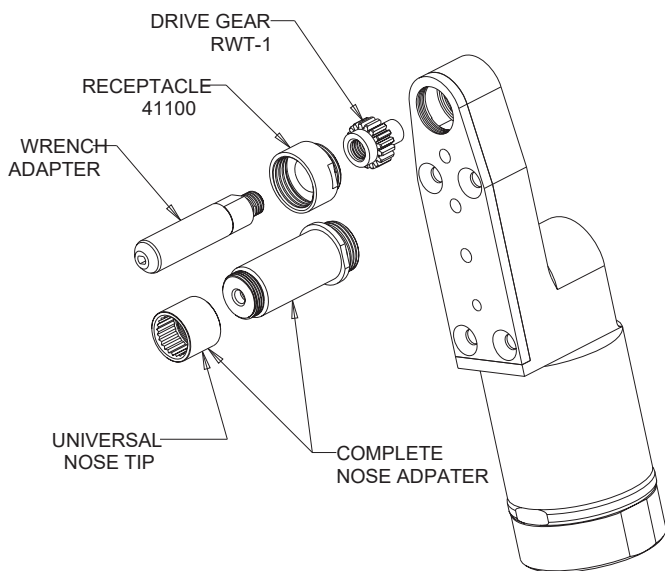

Technical Data

Operating Pressure	90 PSI
Torque Output	220 in-lbs
Motor Speed	500 rpm
Air Consumption (at free speed)	30 cfm
Horse Power Rating	0.5
Weight	3.5lb



Standard Ratchet Hand Tool Adapter Assembly for Composi-Lok 3

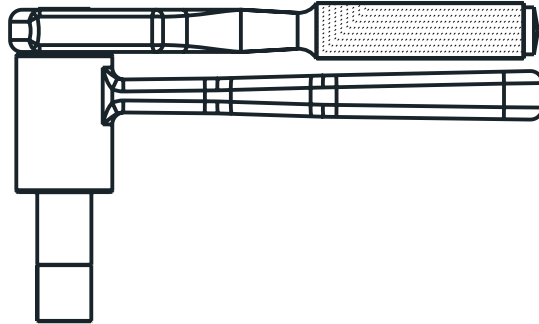

LOK-FAST

Dia	Composi-Lok 3 Series	Complete Assembly	Adapter Assembly	Complete Nose Adapter	Nose Tip Connector	Universal Nose Tip	Wrench Adapter
5/32"		DNH5AA-CL3	DNH5A-CL3	DNH5-8-CL3	DNC5-6	DNUT5-8-CL3	HW1651-CL3
3/16"	MBF2300	DNH6AA-CL3	DNH6A-CL3	DNH5-8-CL3	DNC5-6	DNUT5-8-CL3	HW2001-CL3
1/4"		DNH8AA-CL3	DNH8A-CL3	DNH5-8-CL3	DNC8	DNUT5-8-CL3	HW2601-CL3

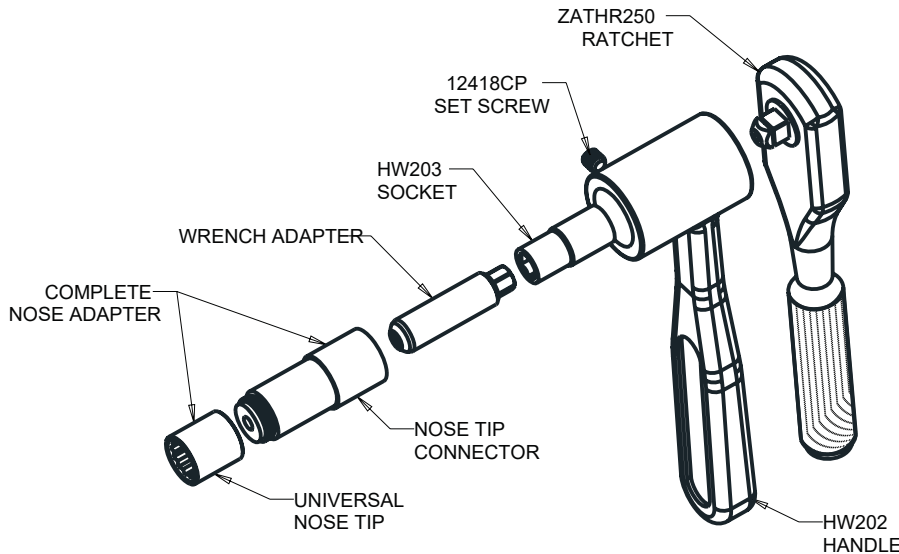

ZEPHYR[®]
T O O L
G R O U P



TOOLS ENGINEERED TO PERFORM

ZEPHYR[®]
SCREWDRIVING TOOLS

KWIK-LOK[™]
TEMPORARY FASTENERS

ZEPHYR[®]
AEROSPACE HAND & PNEUMATIC TOOLS

LOK-FAST[™]
AEROSPACE FASTENER TOOLS

Martin[™]
AIRCRAFT TOOL

LOK-FAST

Jo-Bolts Kits

Blind Fastener Tools

ZEPHYR TOOL GROUP

201 Hindry Avenue
Inglewood, CA 90301

Tel. 310-410-4907 ■ Email: sales@zephyrtoolgroup.com ■ zephyrtoolgroup.com



4000KIT

LOK-FAST

VISU-LOK RATCHET HAND TOOL KIT

INSTRUCTIONS

1. Determine the type (Flush, Protruding, Millable) and size of the fastener being used.
2. Use the right combination of Nose and Wrench Driver.

Example:

fastener: Type Flush size 3/16" (- 6) use:

Nose: HW2002

Wrench Driver Assy: HW2001

3. Insert Wrench Driver Assy into socket and Nose and secure with Set Screw.

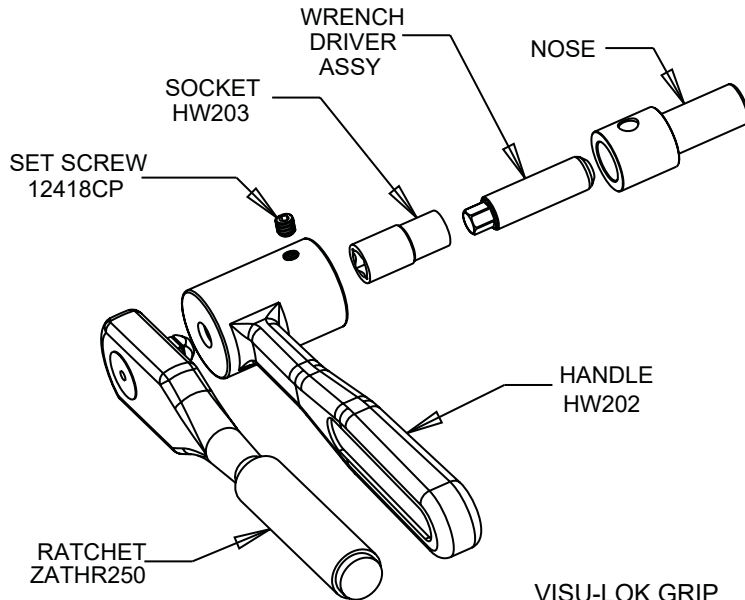

WRENCH DRIVERS ASSY.

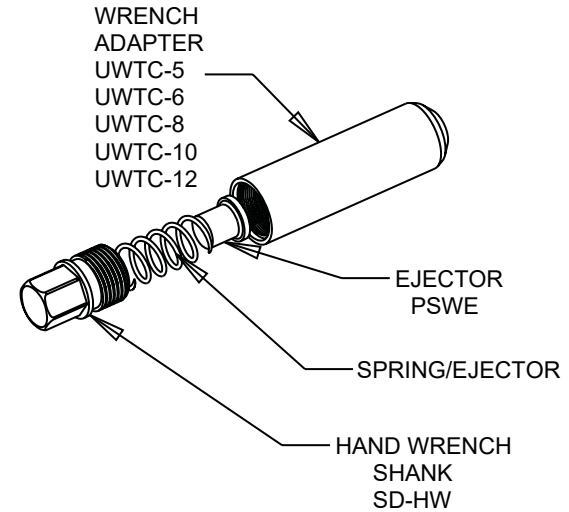

WRENCH DRIVERS ASSY. & SIZE

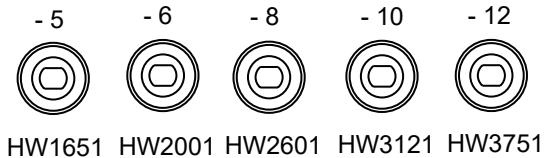

VISU-LOK GRIP LFVLG-1

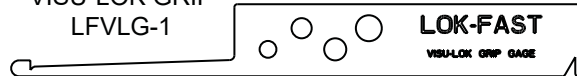

FLUSH TYPE NOSE

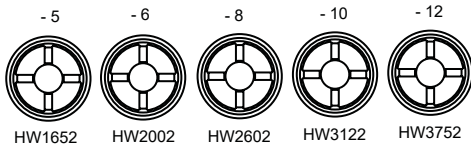

PROTRUDING TYPE NOSE

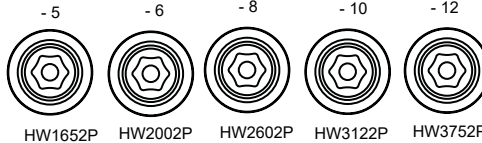

MILLABLE TYPE NOSE

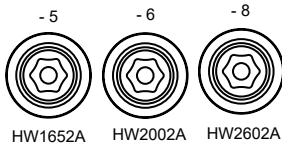

REDUCED FLUSH TYPE NOSE

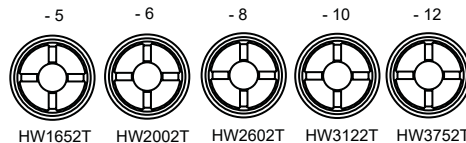

Fastener Driver	Dia.
-5	5/32
-6	3/16
-8	1/4
-10	5/16
-12	3/8



4060 Kit Composi-Lok Right Angle Master Torque Driver Assembly

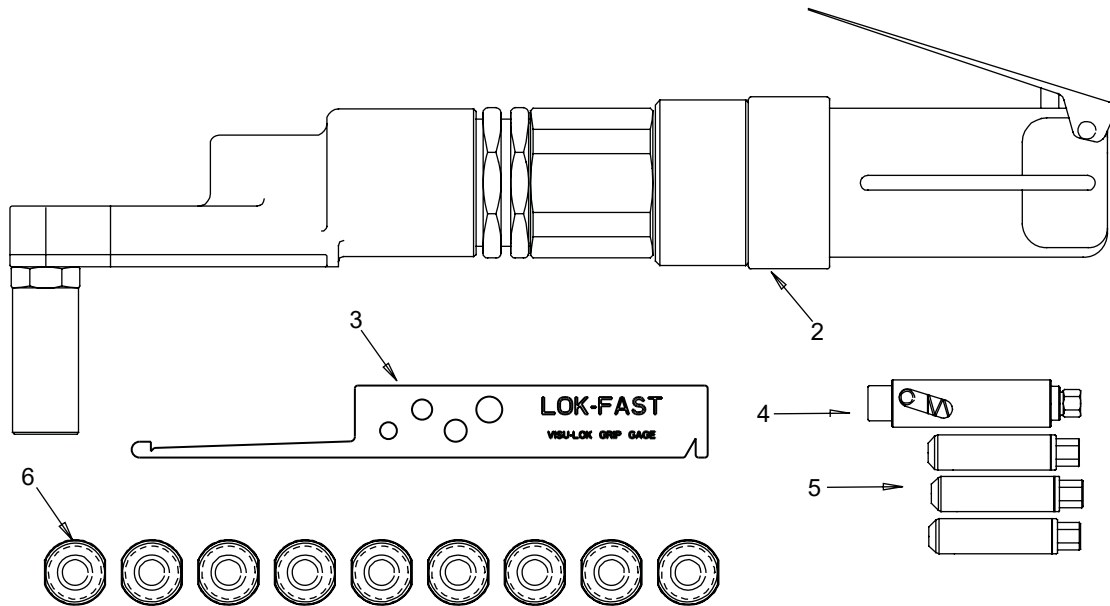

Item	Part #	Description
1	4020-4	Tool Box
2	7440M-BF	Complete Driver Assy.l
3	LFCLG-1	Composi-Lok Grip Gauge
4	MTD502-BF	Master Torque Driver
5	TD5651-BF	Fastener Driver -5
	TD5001-BF	Fastener Driver -6
	TD5601-BF	Fastener Driver -8
6	TD5652T-BF	Reduced Flush Nose -5

Item	Part #	Description
6	TD5652P-BF	Protruding Nose 5
	TD5652-BF	Flush -5
	TD5002T-BF	Reduced Flush Nose -6
	TD5002P-BF	Protruding Nose -6
	TD5002-BF	Flush Nose -6
	TD5602T-BF	Reduced Flush Nose -8
	TD5602P-BF	Protruding Nose -8
	TD5602-BF	Flush Nose -8



4070KIT

VISU-LOK RIGHT ANGLE TORQUE RESPONSIVE KIT



INSTRUCTIONS

1. Determine the type (Flush, Protruding, Millable, Reduced Flush) and size of the fastener being used.
2. Use the right combination of Nose and Master Torque Driver.

Example:

fastener: Type Flush size 3/16" (- 6) use:

Nose: PT4002

Master Torque Driver Assy: PT4001

3. Insert Master Torque Driver Assy into hood and screw on Nose.

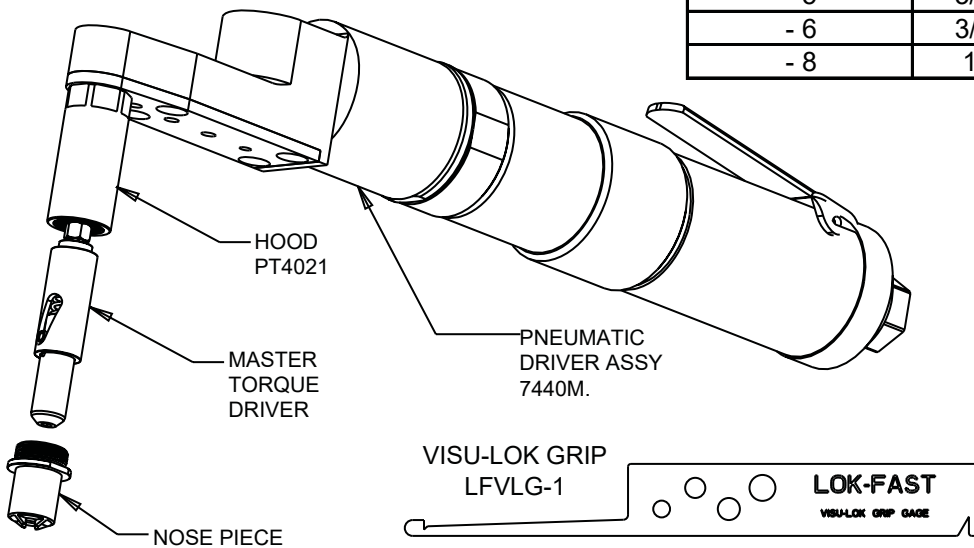

Fastener Driver	Dia.
- 5	5/32
- 6	3/16
- 8	1/4

NOSE PIECES

FLUSH TYPE NOSE

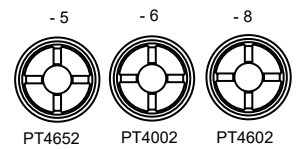

PROTRUDING TYPE NOSE

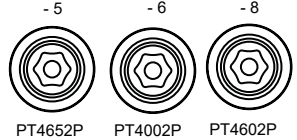

MILLABLE TYPE NOSE

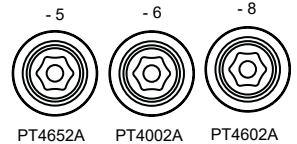

REDUCED FLUSH TYPE NOSE

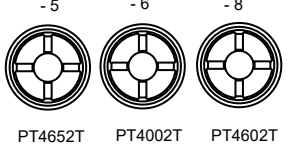

MASTER TORQUE DRIVERS ASSY & SIZE

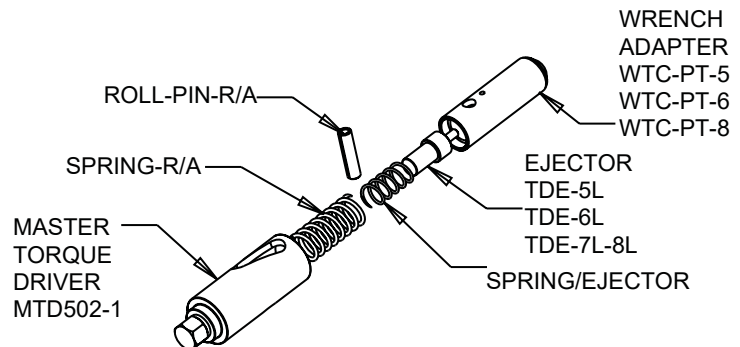
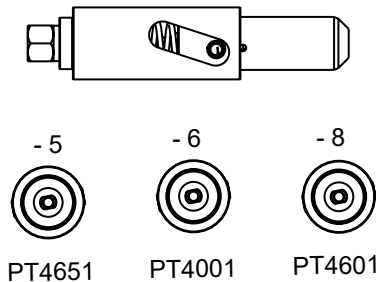



4080 KIT
Composi-Lok® Pistol
Master Torque Driver

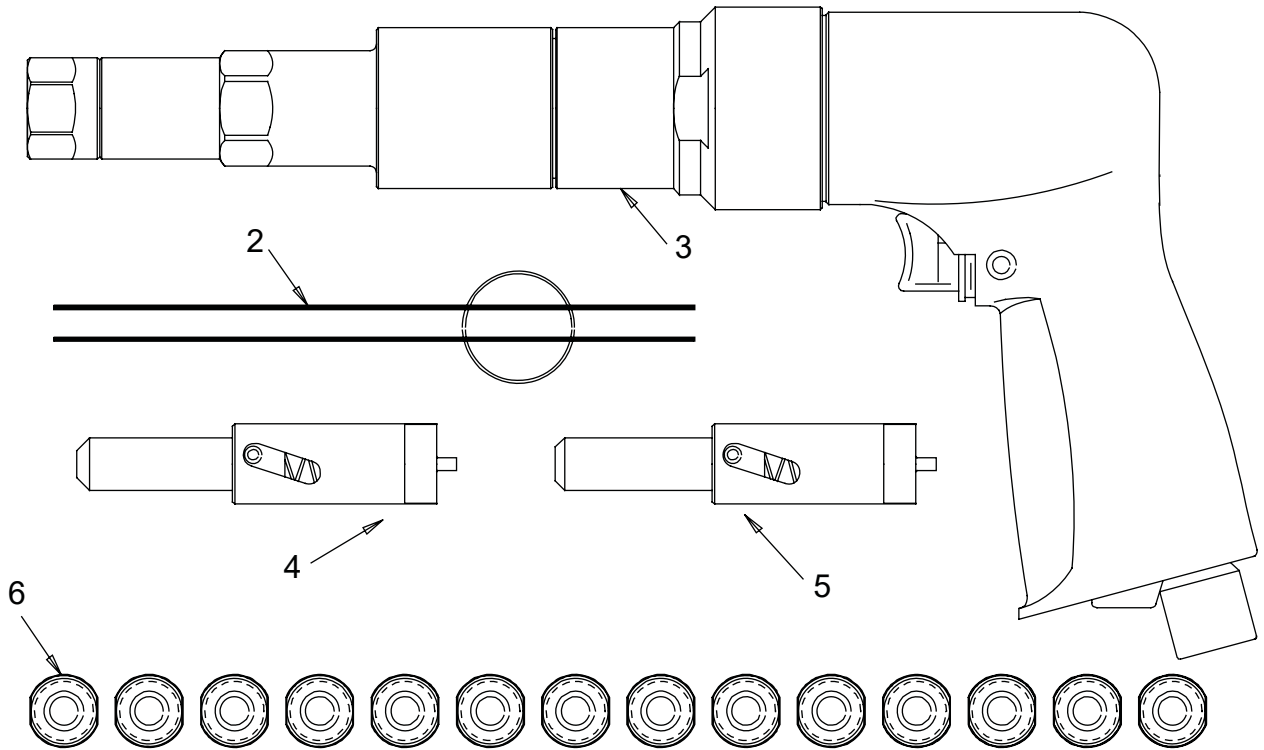

Item	Part #	Description
1	4020-4	Tool Box
2	S540MTD-BF	Ratchet Hand Tool
3	LFCLG-1	Composi-Lok Grip Gauge
	LFCLG-2	Composi-Lok Grip Gauge
4	PT10-BF	Fastener Driver -10
5	PT12-BF	Fastener Driver -12
6	TD1651-BF	Fastener Driver -5
	TD2001-BF	Fastener Driver -6
	TD2601-BF	Fastener Driver -8
	PW3652T-BF	Reduced Flush Nose -5
	PW3652P-BF	Protruding Nose -5
	PW3652-BF	Flush Nose -5

Item	Part #	Description
6	PW3002T-BF	Reduced Flush Nose -6
	PW3002P-BF	Protruding Nose -6
	PW3002-BF	Flush Nose -6
	PW3602T-BF	Reduced Flush Nose -8
	PW3602P-BF	Protruding Nose -8
	PW3602-BF	Flush Nose -8
	PT10FT-BF	Reduced Flush Nose -10
	PT10P-BF	Protruding Nose -10
	PT10F-BF	Flush Nose -10
	PT12FT-BF	Reduced Flush Nose -12
	PT12P-BF	Protruding Nose -12
	PT12F-BF	Flush Nose -12



4090KIT

VISU-LOK PISTOL MASTER TORQUE DRIVER



INSTRUCTIONS

1. Determine the type (Flush, Protruding, Millable) and size of the fastener being used.

2. Use the right Adapter Assy.

Example:

fastener: Type Flush size 3/16" (- 6) use:

Adapter Assy: TD200

3. Insert Driver Assy into slot on Torque Driver Assy (MTD302) screw on Hood Reducer and screw on Nose piece.

4. For size 12, remove torque driver assy., (MTD302) and Hood Reducer, (PT3021R), insert Adapter Assy., (PT375 or PT375P) into Clutch Driver, (PT3022) and Nose piece into Hood, (S1375-20).

Fastener Driver	Dia.
- 5	5/32
- 6	3/16
- 8	1/4
- 10	5/16
- 12	3/8

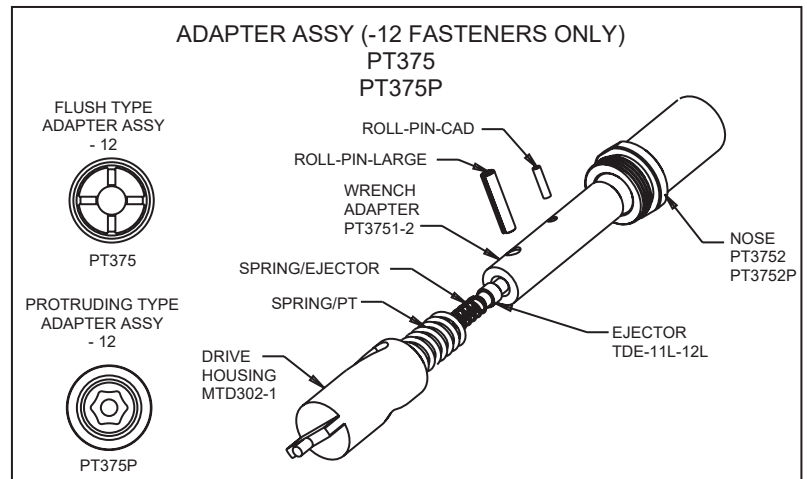
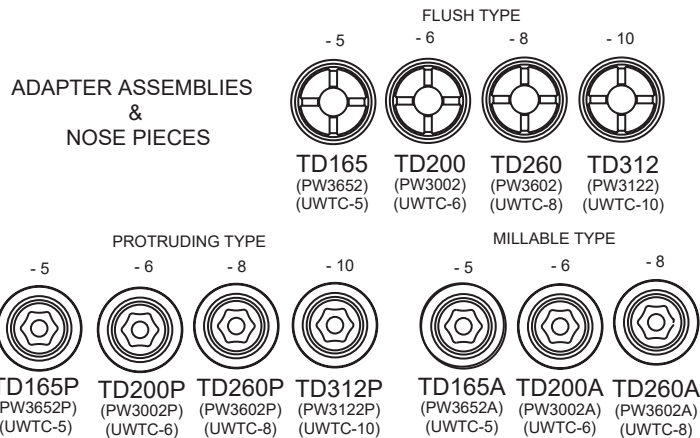
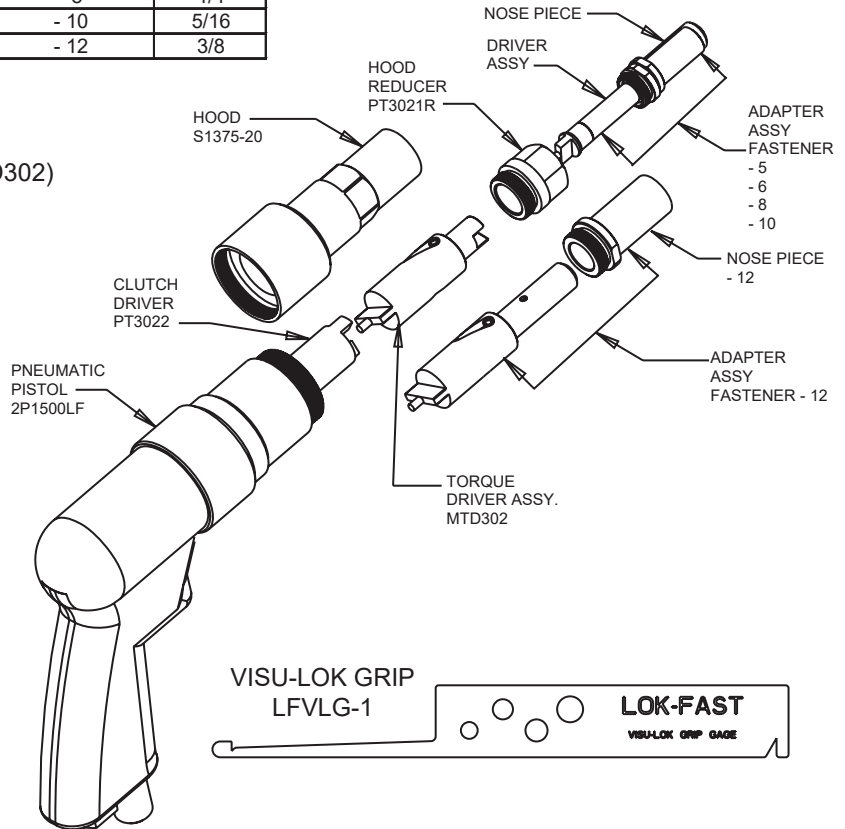
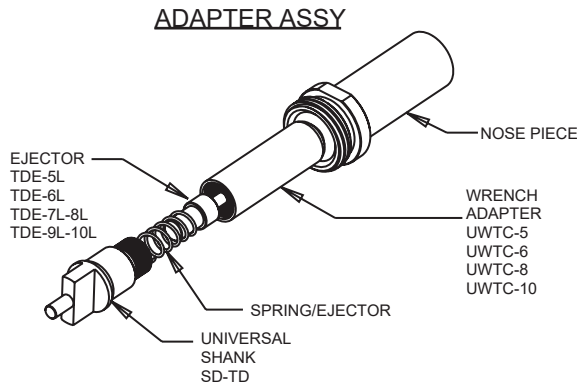



CLHK-101 Composi-Lok Ratchet Hand Tool Kit

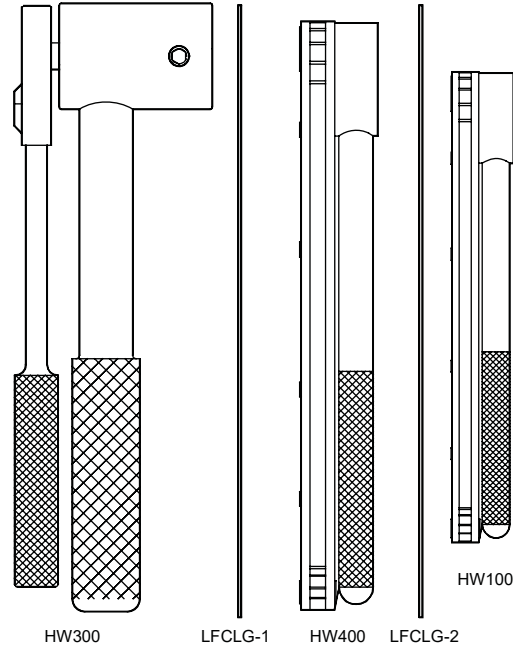
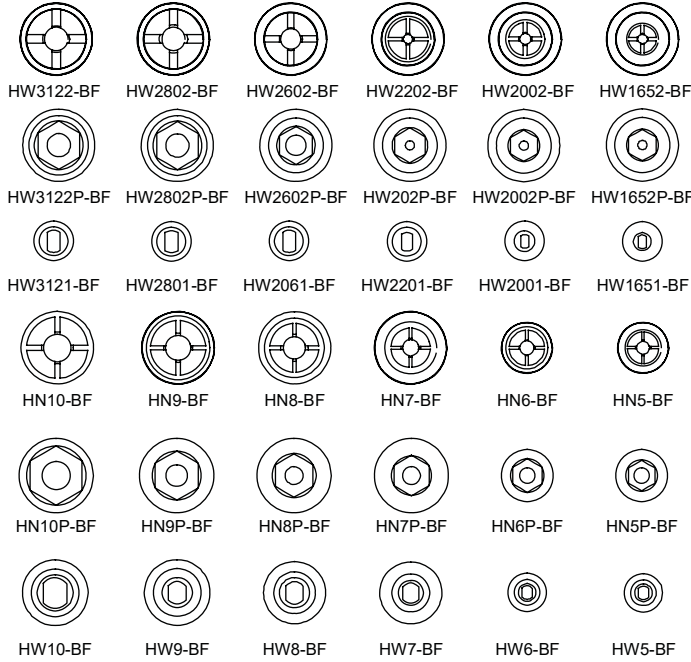

CLIIHK-101 Composi-LokII Ratchet Hand Tool Kit

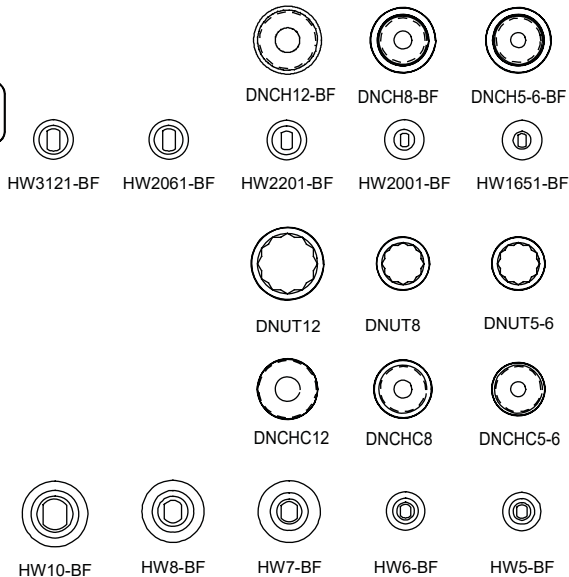
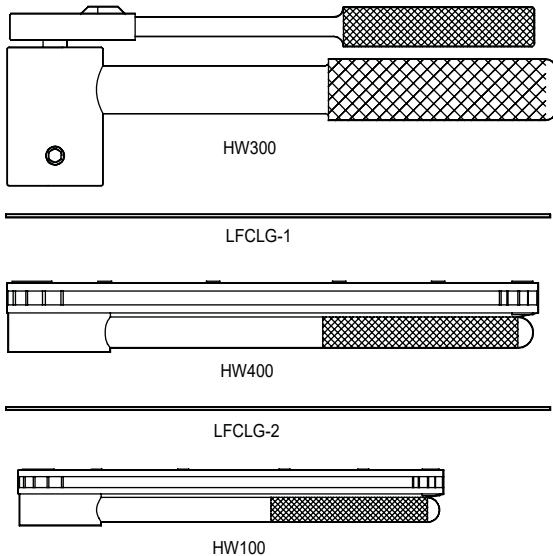



LOK-FAST

VLHK-101

VISU-LOK RATCHET HAND TOOL KIT FLUSH AND PROTRUDING

INSTRUCTIONS

1. Determine the type (Flush, Protruding), extended or close quarter application and size of the fastener being used.
2. Use the right combination of Nose and Wrench Driver.

Example:

fastener: Type Flush size 3/16" (- 6) use:

Nose: HW2002 (Extended) or HN6 (Close Quarter)

Wrench Driver Assy: HW2001 (Extended) or HW6 (close Quarter)

3. Insert Wrench Driver into socket or Handle and Nose, secure with Set Screw.

Fastener Driver	Dia.
-5	5/32
-6	3/16
-8	1/4
-10	5/16

WRENCH DRIVERS ASSY. & SIZE

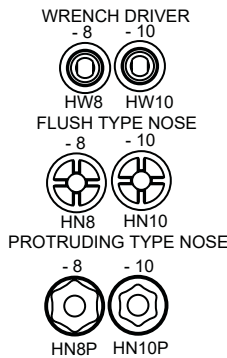
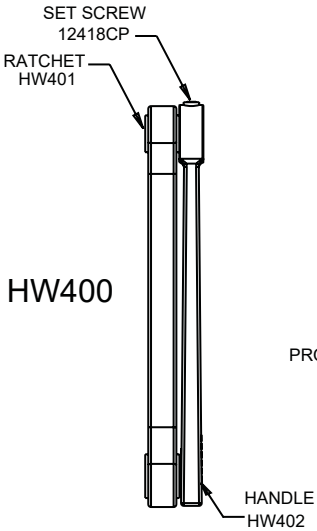
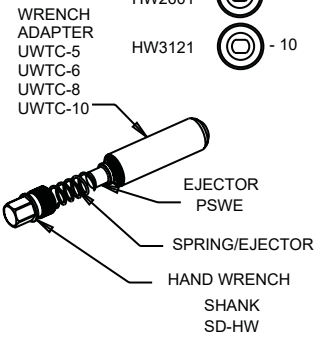
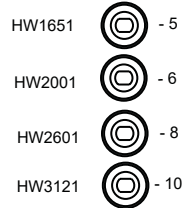

HW100

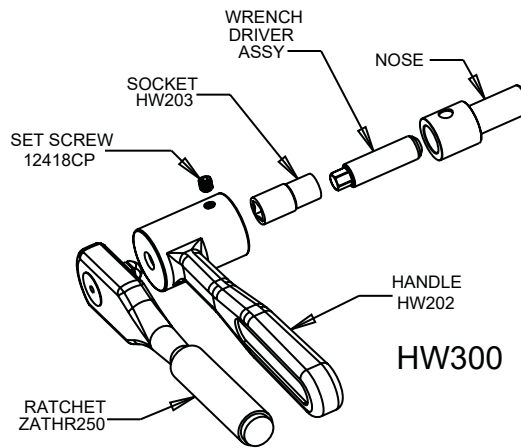

HW300

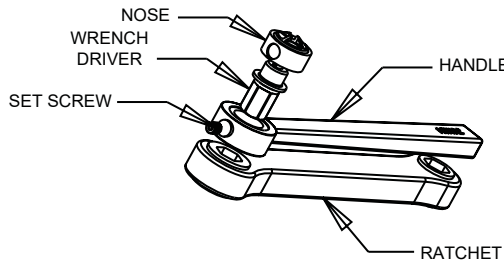

RATCHET HAND TOOL
CLOSE QUARTER

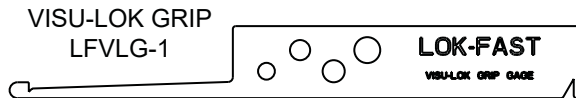
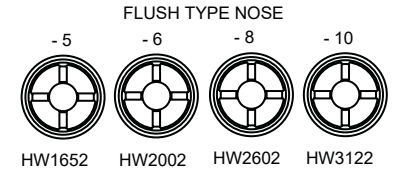
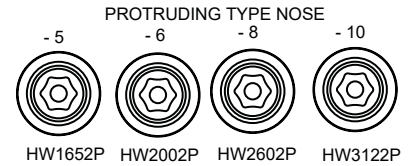



LOK-FAST

VLHK-102

VISU-LOK RATCHET HAND TOOL KIT FLUSH AND PROTRUDING

INSTRUCTIONS

1. Determine the type (Flush, Protruding) and size of the fastener being used.
2. Use the right combination of Nose and Wrench Driver.

Example:

fastener: Type Flush size 3/16" (- 6) use:

Nose: HW2002

Wrench Driver Assy: HW2001

3. Insert Wrench Driver Assy into socket and Nose and secure with Set Screw.

Fastener Driver	Dia.
- 5	5/32
- 6	3/16
- 8	1/4

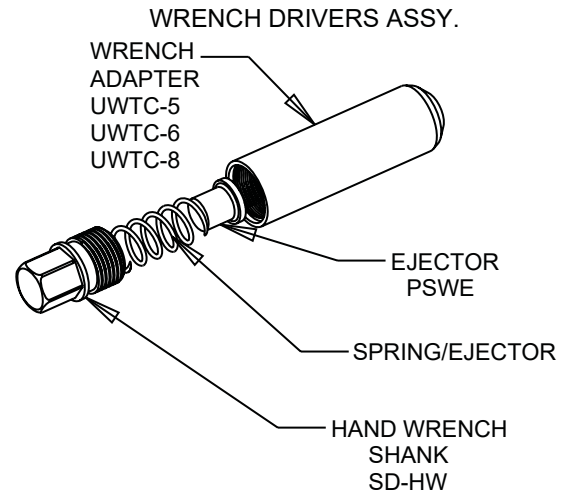
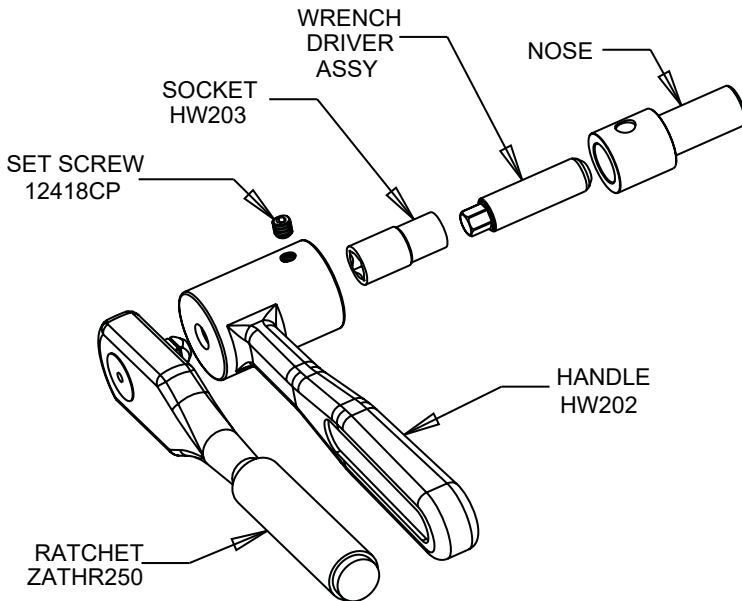

WRENCH DRIVERS ASSY. & SIZE

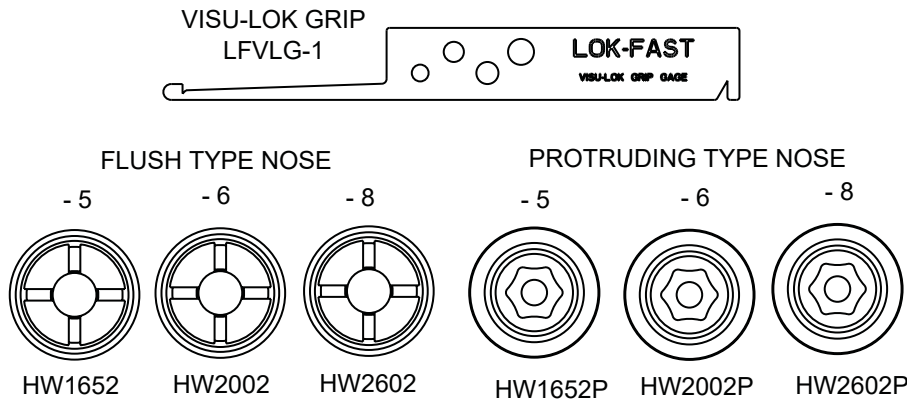



LOK-FAST

3060KIT

VISU-LOK RATCHET HAND TOOL KIT

INSTRUCTIONS

1. Determine the type (Flush, Protruding, Millable) and size of the fastener being used.
2. Use the right combination of Nose and Wrench Driver.

Example:

fastener: Type Flush size 3/16" (- 6) use:

Nose: HW2002

Wrench Driver Assy: HW2001

3. Insert Wrench Driver Assy into socket and Nose and secure with Set Screw.

Fastener Driver	Dia.
- 5	5/32
- 6	3/16
- 8	1/4

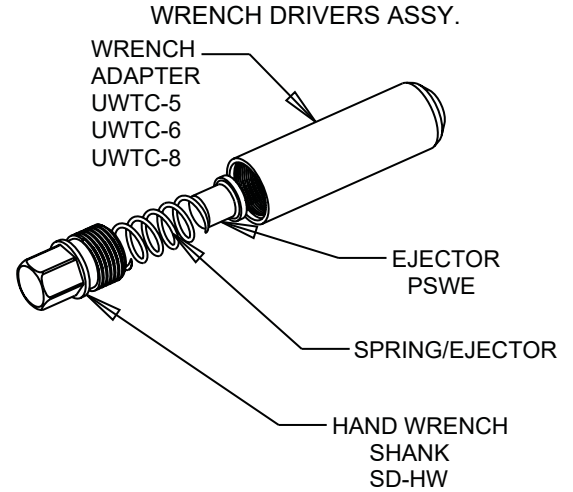
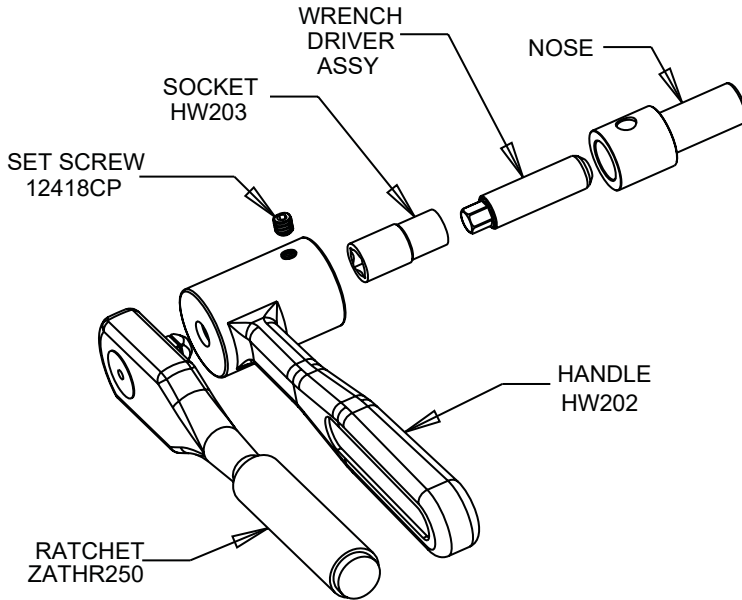

WRENCH DRIVERS ASSY. & SIZE

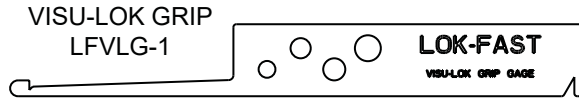

FLUSH TYPE NOSE

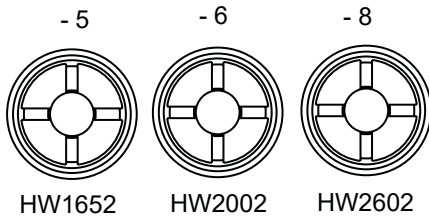

PROTRUDING TYPE NOSE

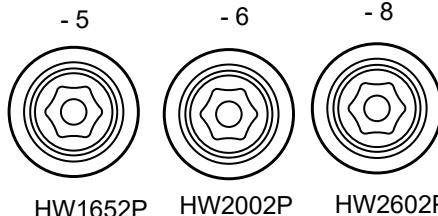

MILLABLE TYPE NOSE

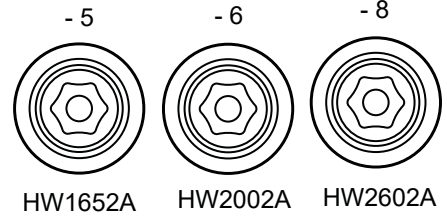



LOK-FAST

HDO-KIT9

VISU-LOK SERIES HAND DRILL-OUT KIT

INSTRUCTIONS

1. Determine the type (Flush, Protruding, Millable) and size of the fastener being used.
2. Select the appropriate tool part number.

Fastener Driver	Dia.	Drill Size
-5	5/32	9/64
-6	3/16	5/32
-8	1/4	13/64

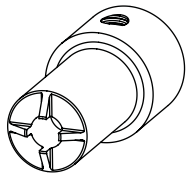
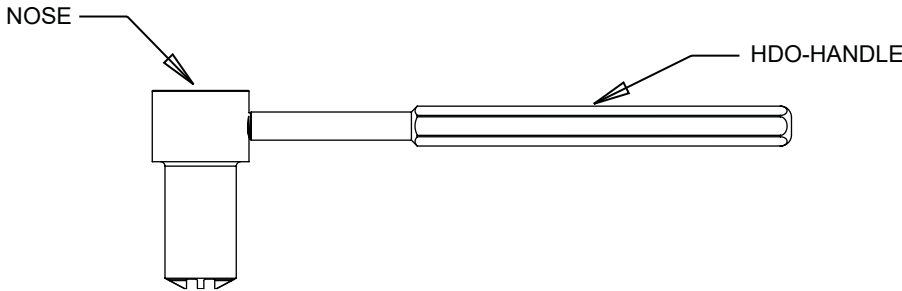
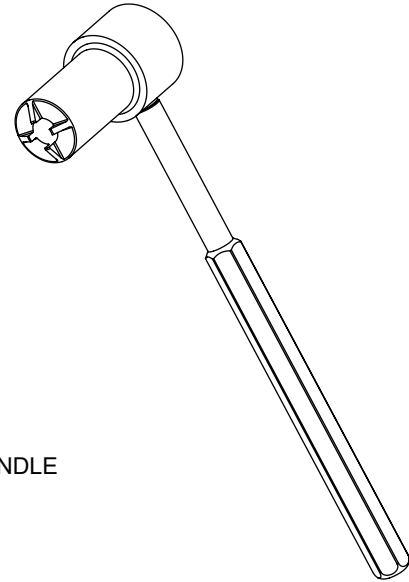

FLUSH TYPE NOSE

-5

-6

-8

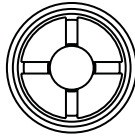
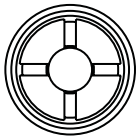
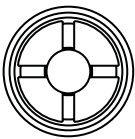

1652/HDO

2002/HDO

2602/HDO

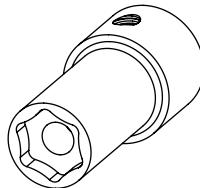

PROTRUDING TYPE NOSE

-5

-6

-8

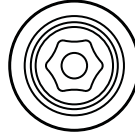
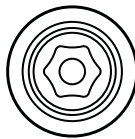
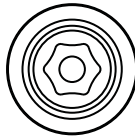

1652P/HDO

2002P/HDO

2602P/HDO

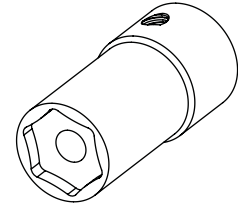

MILLABLE TYPE NOSE

-5

-6

-8

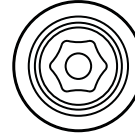
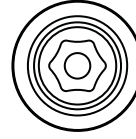

1652A/HDO

2002A/HDO

2602A/HDO

